



Installation and user manual
High-efficiency wall-hung gas boiler

AMC PRO EVO

35

45

65

90

115

Dear Customer,

Thank you very much for buying this appliance. Please read through the manual carefully before using the product, and keep it in a safe place for later reference. In order to ensure continued safe and efficient operation we recommend that the product is serviced regularly. Our service and customer service organisation can assist with this. We hope you enjoy years of problem-free operation with the product.

Contents

1	Safety	6
1.1	General safety instructions	6
1.2	Safety instructions for the installer	7
1.3	Safety instructions for the end user	7
1.4	Liabilities	8
1.4.1	Manufacturer's liability	8
1.4.2	Installer's liability	8
1.4.3	User's liability	9
2	About this manual	9
2.1	General	9
2.2	Additional documentation	9
2.3	Symbols used in the manual	9
3	Description of the product	10
3.1	Boiler types	10
3.2	Main components	10
3.3	Introduction to the controls platform	12
4	Before installation	13
4.1	Installation regulations	13
4.2	Location requirements	13
4.3	Requirements for water connections	14
4.3.1	Requirements for the central heating connections	14
4.4	Requirements for the condensate drain	15
4.5	Requirements for the gas connection	15
4.6	Requirements for the flue gas discharge system	15
4.6.1	Classification	15
4.6.2	Material	18
4.6.3	Dimensions of flue gas outlet pipe	19
4.6.4	Length of the flue and air supply pipes	20
4.6.5	Additional guidelines	22
4.7	Requirements for the electrical connections	23
4.8	Water quality and water treatment	23
4.9	Installation examples	23
4.9.1	Symbols used	23
4.9.2	Single boiler - 2 circuits (Direct circuit, Underfloor mixing circuit) - Domestic hot water cylinder with two sensors	25
4.9.3	Single boiler - 3 circuits (Underfloor mixing circuit, Fan coil unit (direct), Swimming pool (direct)) - Domestic hot water cylinder with two sensors	26
4.9.4	Cascade of two boilers - 3 circuits (Mixing circuit, Mixing circuit, Mixing circuit) - Domestic hot water cylinder with two sensors	27
5	Installation	28
5.1	Positioning the boiler	28
5.2	Flushing the system	29
5.3	Connecting the heating system	29
5.4	Connecting the discharge	30
5.5	Connecting the gas pipe	30
5.6	Connecting the air inlet and flue gas outlet	30
5.7	Mounting the outdoor temperature sensor	30
5.8	Electrical connections	31
5.8.1	Quick connect location	31
5.8.2	PCB locations	32
5.8.3	Access to the control box	33
5.8.4	Access to the expansion box	35
5.8.5	Introduction to the CB-23 connection PCB	35
5.8.6	The CB-23 connection PCB	36
5.8.7	The SCB-10 expansion PCB	41
6	Before commissioning	44
6.1	Checklist before commissioning	44
6.1.1	Filling the trap	44
6.1.2	Filling the installation	44

6.1.3	Preparing the gas circuit	44
6.2	Control panel description	45
6.2.1	Control panel components	45
6.2.2	Description of the home screen	45
6.2.3	Description of the main menu	45
6.2.4	Description of the icons in the display	46
7	Commissioning	47
7.1	Commissioning procedure	47
7.2	Gas settings	47
7.2.1	Factory setting	47
7.2.2	Adjusting to a different gas type	48
7.2.3	Checking and setting the gas/air ratio	50
7.3	Final instructions	55
7.3.1	Saving the commissioning settings	56
8	Settings	56
8.1	Introduction to parameter codes	56
8.2	Accessing the installer level	56
8.3	Searching the parameters, counters and signals	57
8.4	Setting the fixed combinations	57
8.4.1	Activating boiler room ventilation	58
8.5	Setting the inputs and outputs	58
8.5.1	Setting the input	58
8.5.2	Setting the output	62
8.6	List of parameters	63
8.6.1	CU-GH22 control unit parameters	63
9	Maintenance	76
9.1	Maintenance regulations	76
9.2	Preparation	76
9.3	Opening the boiler	77
9.4	Standard inspection and maintenance operations	77
9.4.1	Checking the water quality	77
9.4.2	Cleaning the trap	78
9.5	Finalising work	78
9.6	Disposal and recycling	78
9.6.1	Removal	79
10	Troubleshooting	79
10.1	Error codes	79
10.1.1	Display of error codes	79
10.1.2	Warning	80
10.1.3	Blocking	83
10.1.4	Locking	92
10.2	Error history	96
10.2.1	Reading out and clearing the error history	96
11	User instructions	97
11.1	Start-up	97
11.2	Accessing the user level menus	97
11.3	Home screen	97
11.4	Activating holiday programs for all zones	98
11.5	Heating circuit configuration	98
11.6	Changing the heating temperature of a zone	99
11.6.1	Definition of zone	99
11.6.2	Changing the name and symbol of a zone	99
11.6.3	Changing the operating mode of a zone	100
11.6.4	Time program to control the zone temperature	100
11.6.5	Changing the heating activity temperatures	102
11.6.6	Changing the room temperature temporarily	102
11.7	Changing the domestic hot water temperature	103
11.7.1	Domestic hot water configuration	103
11.7.2	Changing the domestic hot water operating mode	103
11.7.3	Time program to control the DHW temperature	104
11.7.4	Changing the comfort and reduced hot water temperature	104

11.7.5	Increasing the domestic hot water temperature temporarily	105
11.8	Switching the summer mode on or off	105
11.9	Changing the operating mode	105
11.10	Changing the control panel settings	105
11.11	Reading the installer's name and phone number	106
11.12	Frost protection	106
11.13	Cleaning the casing	107
11.14	Shut-down	107
12	Technical specifications	107
12.1	Homologations	107
12.1.1	Certifications	107
12.1.2	Unit categories	107
12.1.3	Directives	108
12.1.4	Factory test	108
12.2	Dimensions and connections	109
12.3	Electrical diagram	110
12.4	Technical data	111
12.5	Hydraulic resistance	114
13	Appendix	114
13.1	ErP information	114
13.1.1	Product fiche	114
13.1.2	Package fiche	116
13.2	EC Declaration of conformity	117

1 Safety

1.1 General safety instructions



Danger
Hazardous appliance

Chance of injury for unqualified users.

- This appliance is not intended for use by persons (including children) with reduced physical, sensory or mental capabilities, or lack of experience and knowledge, unless they have been given supervision or instruction concerning use of the appliance by a person responsible for their safety.
- Children must be supervised to ensure that they do not play with the appliance.



Danger
Flue gas leakage

Chance of CO poisoning.

- Fit a CO detector near the appliance.



Danger
Gas fired appliance

Chance of fire.

- Install smoke alarms at suitable locations.



Warning
Hazardous appliance

Chance of injury.

- Installation, commissioning, maintenance, and decommissioning of the appliance and system must only be carried out by a qualified installer in accordance with regulations and the information given in the manual.



Danger of electric shock
High voltages

Risk of electric shock due to an incorrectly installed power cable.

- A damaged power cable must be replaced by the original manufacturer, the manufacturer's dealer or another qualified technician.



Danger of electric shock
High voltages

Risk of electric shock.

- It must be possible to shut off the power to the appliance at all times.



Notice
Frost damage

Damage to the product.

- Only install the appliance in a frost-free area.



Important

The appliance must be accessible at all times.



Important

Keep all delivered documentation near the appliance.



Important

Instruction and warning labels must never be removed or covered. They must be clearly legible throughout the entire service life of the appliance. Damaged or illegible instructions and warning stickers must be replaced immediately.



Important

Modifications to the appliance require the written approval of **De Dietrich**.

1.2 Safety instructions for the installer



Danger **Gas leakage**

Chance of explosion.

- If you smell gas, always do the following:
- Do not use naked flames, do not smoke, and do not operate electrical contacts like a doorbell, light switch or lift button.
- Shut off the gas supply.
- Open the windows.
- Trace possible leaks and seal them off immediately.
- If the leak is upstream of the gas meter, notify the gas company.



Danger **Flue gas leakage**

Chance of CO poisoning.

- If you smell flue gases, always do the following:
- Switch off the boiler.
- Open the windows.
- Trace possible leaks and seal them off immediately.



Warning **Component incompatibility**

Dangerous situations due to mismatching components.

- Use only genuine spare parts.

1.3 Safety instructions for the end user



Danger **Gas leakage**

Chance of explosion.

- If you smell gas, always do the following:
- Do not use naked flames, do not smoke, and do not operate electrical contacts like a doorbell, light switch or lift button.
- Shut off the gas supply.
- Open the windows.
- Evacuate the property.
- Contact a qualified installer.



Danger **Flue gas leakage**

Chance of CO poisoning.

- If you smell flue gases, always do the following:
- Switch off the boiler.
- Open the windows.
- Evacuate the property.
- Contact a qualified installer.



Warning **Hazardous appliance**

Chance of injury for unqualified users.

- The use of the appliance and the system by you as the end-user must be limited to the operations described in the chapter for the user. All other actions may only be undertaken by a qualified installer/engineer.



Caution **Hot parts**

Burn hazard.

- Do not touch the flue gas pipes. The temperature of the flue gas pipes can rise to over 60 °C.



**Caution
Hot parts**

Burn hazard.

- Do not touch radiators for long periods. The temperature of the radiators can rise to over 60 °C.



**Caution
Hot water**

Burn hazard.

- Be careful when using the domestic hot water. The temperature of domestic hot water can rise to over 65 °C.



**Caution
Component wear**

Dangerous situations due to worn components.

- Make sure that the appliance is regularly serviced. Contact a qualified installer or arrange a maintenance contract for the servicing of the appliance.



**Notice
Blocked condensate drain**

Damage to the product.

- Do not modify or seal the condensate drain.
- If a condensate neutralisation system is used, the system must be cleaned regularly in accordance with the instructions provided by the manufacturer.



**Notice
Low water level**

Damage to the product.

- Regularly check the water level and pressure in the heating system.
- Top up the system if the pressure is too low.



**Notice
Frost damage**

Damage to the product.

- Keep the appliance switched on so the frost protection can work. The frost protection does not work if the appliance is switched off.
- Drain the appliance and heating system if you will be away from home for a long time and there is a chance of frost.

1.4 Liabilities

1.4.1 Manufacturer's liability

Our products are manufactured in compliance with the requirements of the various directives applicable. They are therefore delivered with the **CE** marking and any documents necessary. In the interests of the quality of our products, we strive constantly to improve them. We therefore reserve the right to modify the specifications given in this document.

Our liability as manufacturer may not be invoked in the following cases:

- Failure to abide by the instructions on installing and maintaining the product.
- Failure to abide by the instructions on using the product.
- Faulty or insufficient maintenance of the product.

1.4.2 Installer's liability

The installer is responsible for the installation and initial commissioning of the product. The installer must observe the following instructions:

- Read and follow the instructions given in the manuals for the product.
- Install the product in compliance with prevailing legislation and standards.
- For Austria: Install the product in compliance with the regulation of the ÖVGW guidelines.
- Carry out initial commissioning and any checks necessary.
- Explain the installation to the user.
- If maintenance is necessary, warn the user of the obligation to check the product and keep it in good working order.
- Give the user all safety and user instruction manuals provided with the product.

1.4.3 User's liability

To guarantee optimum operation of the system, you must abide by the following instructions:

- Read and follow the instructions given in the manuals for the product.
- Call on a qualified professional to carry out the installation and initial commissioning.
- Have your installer explain the installation to you.
- Have the required inspections and maintenance carried out by a qualified installer.
- Keep the provided manuals in good condition and close to the product.

2 About this manual

2.1 General

This manual is intended for the installer and end user of a AMC PRO EVO appliance.

2.2 Additional documentation

The following documentation is available in addition to this manual:

- Product information
- Service manual

2.3 Symbols used in the manual

This manual contains special instructions, marked with specific symbols. Please pay extra attention when these symbols are used.



Danger of electric shock

Indicates: an imminently hazardous situation

Consequence if not avoided: Will result in death or serious injury.

- This is how to avoid the hazard.



Danger

Indicates: an imminently hazardous situation

Consequence if not avoided: Will result in death or serious injury.

- This is how to avoid the hazard.



Warning

Indicates: a potentially hazardous situation

Consequence if not avoided: Could result in death or serious injury.

- This is how to avoid the hazard.



Caution

Indicates: a potentially hazardous situation

Consequence if not avoided: Could result in minor or moderate injury.

- This is how to avoid the hazard.



Notice

Indicates: a potential risk of damage to the supported product

Consequence if not avoided: Could result in damage to the product or other property.

- This is how to avoid the hazard.



Important

Please note: important information.

The symbols mentioned below are of lower importance, but they can help you navigate or give useful information.



See

Reference to other manuals or pages in this manual.



Helpful information or extra guidance.

►► Direct menu navigation, confirmations will not be shown. Use if you are familiar with the system.

3 Description of the product

3.1 Boiler types

The following boiler types are available:

Tab.1 Boiler types

Name	Output ⁽¹⁾	Output ⁽²⁾
AMC PRO EVO 35 ⁽³⁾	35.0 kW	33.2 kW
AMC PRO EVO 45	42.4 kW	40.0 kW
AMC PRO EVO 65	65.0 kW	60.9 kW
AMC PRO EVO 90	89.5 kW	84.2 kW
AMC PRO EVO 115	109.7 kW	103.9 kW

(1) Nominal output P_{nc} 50/30 °C.
 (2) Nominal output P_n 80/60 °C.
 (3) This boiler type is a AMC PRO EVO 45 configured at 35 kW. Use the AMC PRO EVO 35 information given in this manual.

3.2 Main components

Fig.1 General

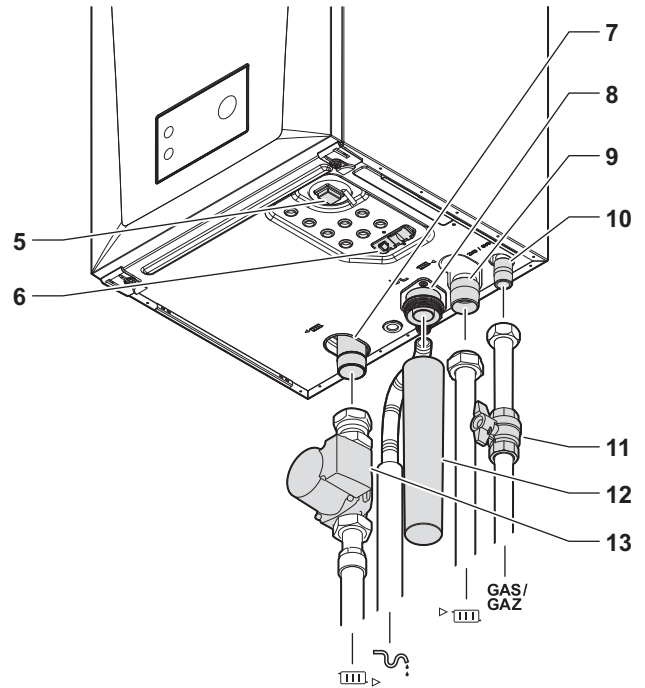
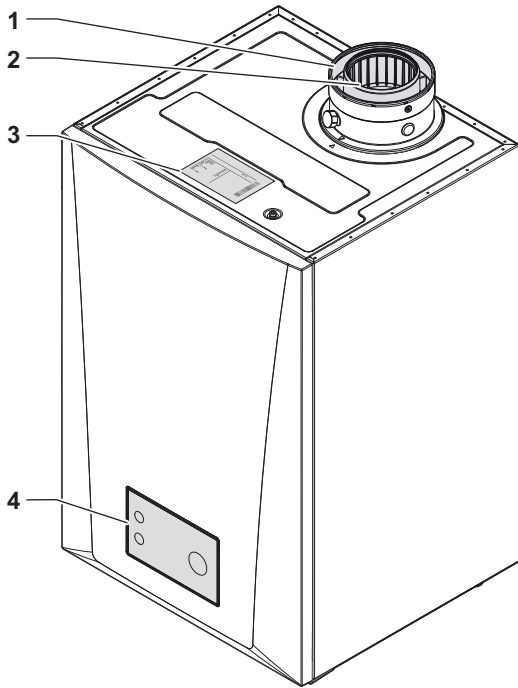

- 1 Air inlet connection
- 2 Flue gas outlet connection
- 3 Data plate
- 4 Control panel

- 5 Power button
- 6 Quick connect
- 7 Return connection
- 8 Condensate connection
- 9 Flow connection
- 10 Gas connection
- 11 Gas cock
- 12 Trap
- 13 Pump
- System return pipe
- Condensate drain pipe
- System flow pipe
- Gas supply pipe

AD-3002806-01

Fig.2 Internal

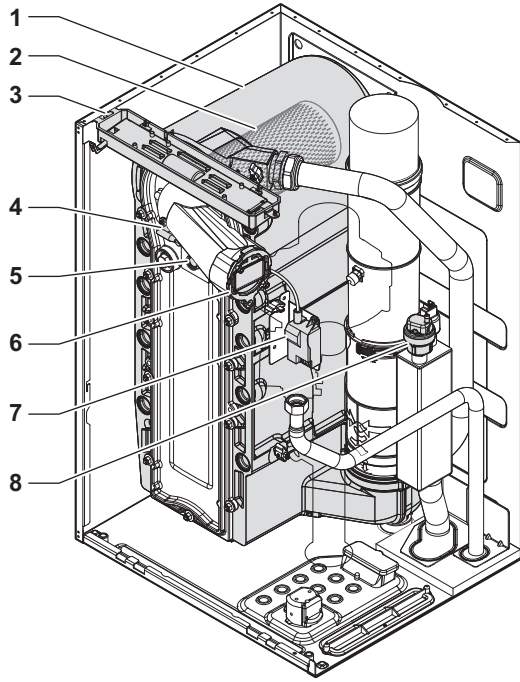

- 1 Heat exchanger
- 2 Burner
- 3 Interior light
- 4 Ignition / ionisation electrode
- 5 Flame inspection glass
- 6 Non-return valve
- 7 Ignition / ionisation transformer
- 8 Automatic air vent

Fig.3 Gas - air unit

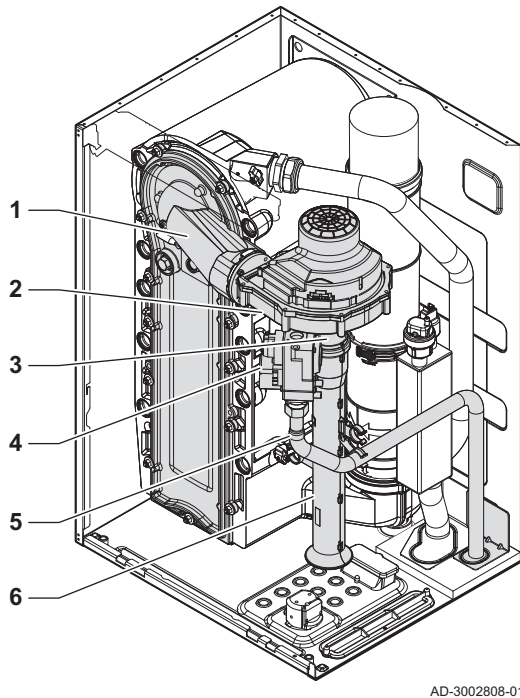

- 1 Front plate with mixing tube
- 2 Fan
- 3 Venturi
- 4 Gas control valve
- 5 Gas supply tube
- 6 Air inlet silencer

Fig.4 Sensors and boxes

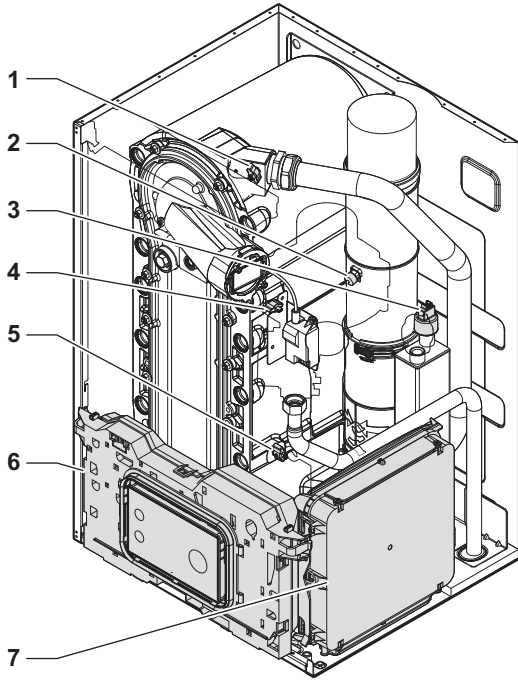

- 1 Flow temperature sensor
- 2 Flue gas temperature sensor
- 3 Water pressure sensor
- 4 Heat exchanger temperature sensor
- 5 Return temperature sensor
- 6 Control box
- 7 Expansion box

AD-3002809-01

3.3 Introduction to the controls platform

The AMC PRO EVO boiler is equipped with the controls platform. This is a modular system, and offers compatibility and connectivity between all products that make use of the same platform.

Fig.5 Generic example

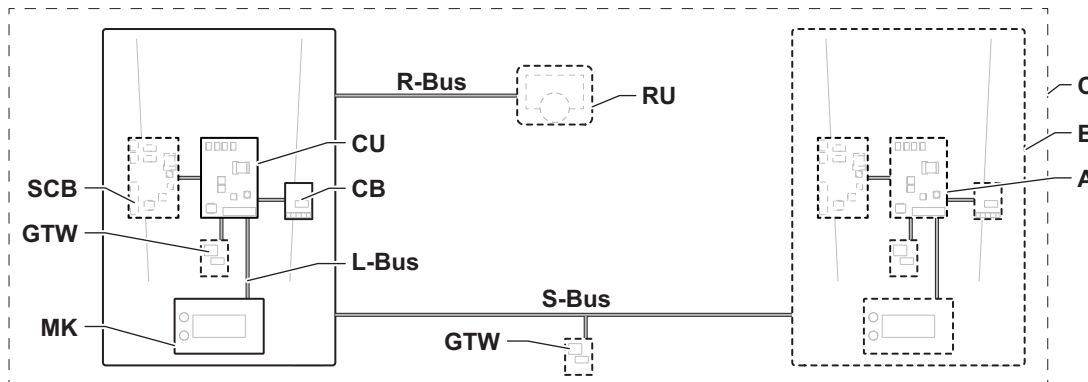

AD-3001366-02

Tab.2 Components in the example

Item	Description	Function
CU	Control Unit: Control unit	The control unit handles all basic functionality of the appliance.
CB	Connection Board: Connection PCB	The connection PCB provides easy access to all connectors of the control unit.
SCB	Smart Control Board: Expansion PCB	An expansion PCB provides extra functionality, like an internal calorifier or multiple zones.
GTW	Gateway: Conversion PCB	A gateway can be fitted to an appliance or system, to provide one of the following: <ul style="list-style-type: none"> • Extra (wireless) connectivity • Service connections • Communication with other platforms
MK	Control panel: Control panel and display	The control panel is the user interface to the appliance.
RU	Room Unit: Room unit (for example, a thermostat)	A room unit measures the temperature in a reference room.
L-bus	Local Bus: Connection between devices	The local bus provides communication between devices.

Item	Description	Function
S-bus	System Bus: Connection between appliances	The system bus provides communication between appliances.
R-bus	Room unit Bus: Connection to a room unit	The room unit bus provides communication to a room unit.
A	Device	A device is a PCB, control panel or a room unit.
B	Appliance	An appliance is a set of devices connected via the same L-bus
C	System	A system is a set of appliances connected via the same S-bus

Tab.3 Specific devices delivered with the AMC PRO EVO boiler

Name visible in display	Software version	Description	Function
CU-GH22	1.0	Control unit CU-GH22	The CU-GH22 control unit handles all basic functionality of the AMC PRO EVO boiler.
MK3	1.98	Control panel Diematic Evolution	The Diematic Evolution is the user interface to the AMC PRO EVO boiler.
SCB-10	1.04	Expansion PCB SCB-10	The SCB-10 provides functionality for one DHW and two central heating zones, a 0-10 V connection for a PWM system pump and a potential-free contact for status notification. Extend the SCB-10 with the AD249 (optional). The AD249 provides functionality for one extra central heating zone and a DHW circulation loop.

4 Before installation

4.1 Installation regulations



Warning
Hazardous appliance
Chance of injury.

- Installation of the appliance must only be carried out by a qualified installer in accordance with regulations and the information given in the manual.

4.2 Location requirements



Danger
Combustible element
Chance of fire

- Never store, even temporarily, combustible products or substances in or near the appliance.



Warning
Heat damage
Damage to the product.

- Do not place the appliance above a heat source or a cooking appliance.



Warning
UV damage
Damage to the product.

- Do not locate the appliance in direct or indirect sunlight.



Notice
Frost damage
Damage to the product.

- Only install the appliance in a frost-free area.



Notice
Insufficient support
 Damage to the product.

- Make sure the wall or construction can hold the weight of the appliance.



Important

- An earthed electrical connection must be available close to the appliance.
- A connection to the drain must be available close to the appliance.

When choosing the best installation location, consider:

- The regulations.
- The required installation space.
- The required space around the appliance for good access and to facilitate maintenance.
- The required space under the appliance for the installation and removal of the trap.
- The permitted position of the flue gas outlet and/or air supply opening.
- The evenness of the surface.

When installing in a closed cupboard (or similar), consider:

- The minimum distance between the appliance and the walls of the cupboard.
- The required ventilation openings with a minimum cross section: $S1 + S2 = 150 \text{ cm}^2$. This will prevent the following hazards:
 - Accumulation of gas in the closed cupboard.
 - Heating of the closed cupboard.

Fig.6 Location requirements

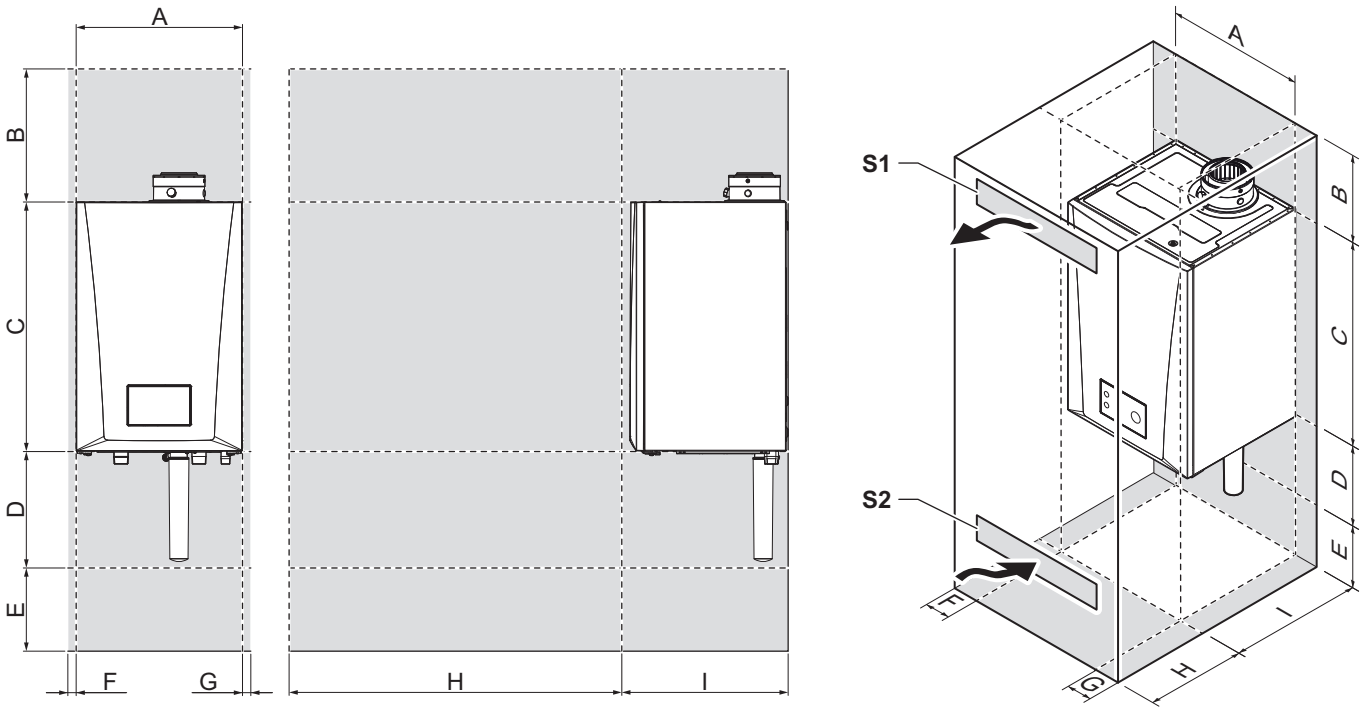

- A 500 mm
- B $\geq 400 \text{ mm}$
- C 750 mm
- D 350 mm
- E $\geq 250 \text{ mm}$

- F $\geq 15 \text{ mm}$
- G $\geq 15 \text{ mm}$
- H $\geq 1000 \text{ mm}$
- I 500 mm

AD-3002836-02

4.3 Requirements for water connections

- Before installation, check that the connections meet the set requirements.
- Carry out any welding work required at a safe distance from the appliance.
- If using synthetic pipes, follow the manufacturer's instructions.

4.3.1 Requirements for the central heating connections

- We recommend to install an isolation valve in the flow pipe and return pipe to facilitate servicing work.

- We recommend to install a fill and drain valve in the return pipe to facilitate servicing work. Place it between the isolation valve and the appliance.
- We recommend to install an expansion vessel in the return pipe. Place it between the isolation valve and the appliance.
- We recommend to install a central heating filter in the return pipe to prevent clogging of internal components.

4.4 Requirements for the condensate drain

- The drain pipe must be Ø 32 mm or larger, terminating in the drain.
- Use only plastic material for the discharge pipe due to the acidity (pH 2 to 5) of the condensate.
- Fit a trap in the drain pipe.
- The drain pipe must slope down at least 30 mm per metre, the maximum horizontal length is 5 metres.
- Do not make a fixed connection in order to prevent an overpressure in the trap.

4.5 Requirements for the gas connection

- Carry out any welding work required at a safe distance from the boiler.
- Before installing, check that the gas meter has sufficient capacity. Take into account the consumption of all appliances. Notify the local energy company if the gas meter has insufficient capacity.
- An installed boiler gas cock must always be accessible.
- We recommend installing a gas filter to prevent clogging of the gas control valve.
- For France: Pipe diameters must be defined in accordance with ATG's (Association Technique de Gaz) B171 specifications.

4.6 Requirements for the flue gas discharge system

4.6.1 Classification



Important

- The installer is responsible for choosing the correct type, diameter, and length of the flue system.
- Always use connection materials, roof terminal and/or horizontal flue terminal supplied by the same manufacturer. Consult the manufacturer for compatibility details.
- The use of flue systems from other manufacturers is allowed in addition to the recommended manufacturers listed in this manual. Use is only allowed when all our requirements are met and the description of flue system C_{63(X)} is respected.

Tab.4 Type of flue system: B₂₃ - B_{23P}

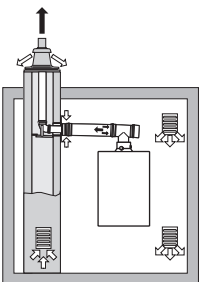
Principle	Description	Recommended manufacturers ⁽¹⁾
 <p>AD-3000924-01</p>	<p>Room-ventilated version.</p> <ul style="list-style-type: none"> • Without down-draught diverter. • Flue gas discharge via the roof. • Air supply from the installation area. • The air inlet connection of the boiler must stay open. • The installation area must be vented to ensure sufficient air supply. The vents must not be obstructed or shut off. • The IP rating of the boiler is lowered to IP20. 	<p>Connection material and roof terminal:</p> <ul style="list-style-type: none"> • Cox Geelen • Poujoulat • Ubbink

(1) The material must also satisfy the material property requirements from the relevant chapter.

Tab.5 Type of flue system: B₃₃

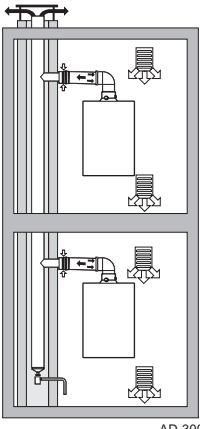
Principle	Description	Recommended manufacturers ⁽¹⁾
 <p style="text-align: center;">AD-3000925-01</p>	<p>Room-ventilated version.</p> <ul style="list-style-type: none"> • Without down-draught diverter. • Joint flue gas discharge via the roof, with guaranteed natural draft (at all times underpressure in the joint discharge duct). • Flue rinsed with air, air from the installation area (special construction). • The IP rating of the boiler is lowered to IP20. 	<p>Connection material:</p> <ul style="list-style-type: none"> • Cox Geelen • Poujoulat • Ubbink
<p>(1) The material must also satisfy the material property requirements from the relevant chapter.</p>		

Tab.6 Type of flue system: C_{13(X)}

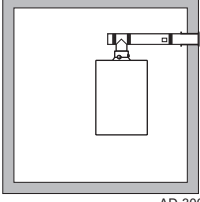
Principle	Description	Recommended manufacturers ⁽¹⁾
 <p style="text-align: center;">AD-3000926-01</p>	<p>Room-sealed version.</p> <ul style="list-style-type: none"> • Flue gas discharge in the outside wall. • The air inlet is in the same pressure zone as the flue (for example a horizontal flue terminal). • Parallel wall terminal not permitted. 	<p>Horizontal flue terminal and connection material:</p> <ul style="list-style-type: none"> • Cox Geelen
<p>(1) The material must also satisfy the material property requirements from the relevant chapter.</p>		

Tab.7 Type of flue system: C_{33(X)}

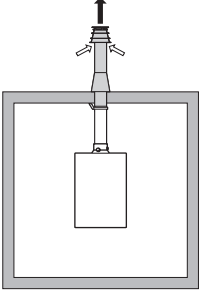
Principle	Description	Recommended manufacturers ⁽¹⁾
 <p style="text-align: center;">AD-3000927-01</p>	<p>Room-sealed version.</p> <ul style="list-style-type: none"> • Flue gas discharge via the roof. • The air inlet is in the same pressure zone as the flue (for example a concentric roof terminal). 	<p>Roof terminal and connection material</p> <ul style="list-style-type: none"> • Cox Geelen • Poujoulat • Ubbink
<p>(1) The material must also satisfy the material property requirements from the relevant chapter.</p>		

Tab.8 Type of flue system: C_{43P}

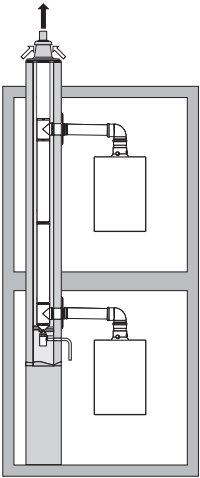
Principle ⁽¹⁾	Description	Recommended manufacturers ⁽²⁾
 <p>AD-3000928-01</p>	<p>Combined air inlet and flue system (common shared flue system) with overpressure.</p> <ul style="list-style-type: none"> • Concentric (preferably). • Parallel (if concentric is not possible). • Minimum permitted pressure difference between the air inlet and the flue is -200 Pa (including -100 Pa wind pressure). • The duct must be designed for a nominal flue gas temperature of 25 °C. • Place a condensation drain, equipped with a trap, at the bottom of the duct. • Maximum permissible recirculation of 10%. • The common shared flue system must be appropriate for a pressure of at least 200 Pa. • The roof terminal must be designed for this configuration and must cause a draught in the duct. • A draught diverter is not permitted. <p>i Important</p> <ul style="list-style-type: none"> • Modify the fan speed for this configuration. • Contact us for more information. 	<p>Connecting material to the common shared flue system:</p> <ul style="list-style-type: none"> • Cox Geelen • Poujoulat • Ubbink
<p>(1) EN 15502-2-1: 0.5 mbar suction due to negative pressure. (2) The material must also satisfy the material property requirements from the relevant chapter.</p>		

Tab.9 Type of flue system: C₅₃

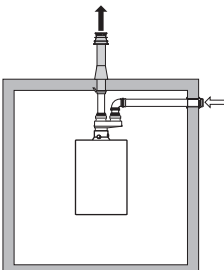
Principle	Description	Recommended manufacturers ⁽¹⁾
 <p>AD-3003420-01</p>	<p>Connection in different pressure zones.</p> <ul style="list-style-type: none"> • Closed unit. • Separate air inlet and flue. • Discharging into various pressure areas. • The air inlet and flue must not be placed on opposite walls. 	<p>Connection material and roof terminal:</p> <ul style="list-style-type: none"> • Cox Geelen • Poujoulat • Ubbink
<p>(1) The material must also satisfy the material property requirements from the relevant chapter.</p>		

Tab.10 Type of flue system: C_{63(X)}

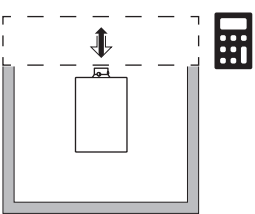
Principle	Description	Recommended manufacturers ⁽¹⁾
 <p>AD-3003358-01</p>	<p>This system is supplied by us without an air inlet and flue. When selecting the material, please note the following:</p> <ul style="list-style-type: none"> • Condensed water must flow back to the boiler. • The material must be resistant to the flue gas temperature of this boiler. • Maximum permissible recirculation of 10%. • The air inlet and flue must not be placed on opposite walls. • Minimum permitted pressure difference between the air inlet and the flue is -200 Pa (including -100 Pa wind pressure). • A common shared flue system with overpressure is not permitted. 	<p>Use is only allowed when all our requirements are met and the description of this flue system type is respected.</p>
<p>(1) The material must also satisfy the material property requirements from the relevant chapter.</p>		

Tab.11 Type of flue system: C_{93(X)}

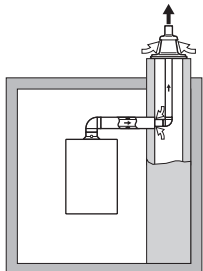
Principle ⁽¹⁾	Description	Recommended manufacturers ⁽²⁾
 <p style="text-align: center; font-size: small;">AD-3000931-02</p>	<p>Room-sealed version.</p> <ul style="list-style-type: none"> • Air inlet and flue in shaft or duct: <ul style="list-style-type: none"> - Concentric. - Air supply from existing shaft or duct. - Flue gas discharge via the roof. - Air inlet is in the same pressure zone as the flue. 	<p>Connection material and roof terminal:</p> <ul style="list-style-type: none"> • Cox Geelen • Poujoulat • Ubbink
<p>(1) See table for shaft or duct requirements. (2) The material must also satisfy the material property requirements from the relevant chapter.</p>		

Tab.12 Minimum dimensions of shaft or duct C_{93(X)}

Version (D)	Without air supply		With air supply	
Rigid 80 mm	Ø 130 mm	□ 130 x 130 mm	Ø 140 mm	□ 130 x 130 mm
Rigid 100 mm	Ø 160 mm	□ 160 x 160 mm	Ø 170 mm	□ 160 x 160 mm
Concentric 80/125 mm	Ø 145 mm	□ 145 x 145 mm	Ø 145 mm	□ 145 x 145 mm
Concentric 100/150 mm	Ø 170 mm	□ 170 x 170 mm	Ø 170 mm	□ 170 x 170 mm

Fig.7 Minimum dimensions of shaft or duct C_{93(X)}

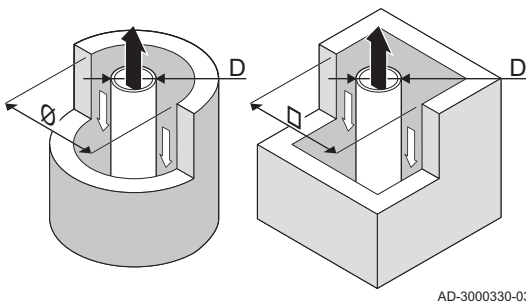

Important

The shaft must comply with the airtightness requirements of the local regulations.



Important

- Always clean shafts thoroughly when using flue liners and/or an air inlet connection.
- It must be possible to inspect the flue liner.

4.6.2 Material



Danger

Flue gas leakage

Chance of CO poisoning.

- Do not combine pipes, coupling, roof terminals, and connection methods from different manufacturers. This also applies to common shared flue ducts.
- Follow the instructions provided by the manufacturer of the flue gas material.
- The materials used must comply with the prevailing regulations and standards.
- Please contact us when using flexible flue gas outlet material.

Use the string on the flue gas outlet material to check whether it is suitable for use on this appliance.

Fig.8 Sample string

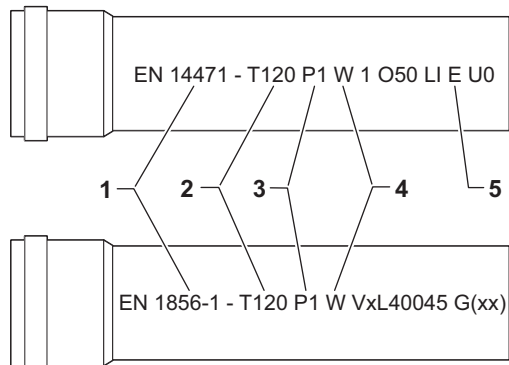

AD-3001120-01

- 1 **EN 14471 or EN 1856-1**: The material is CE approved according to this standard. For plastic this is EN 14471, For aluminium and stainless steel this is EN 1856-1.
- 2 **T120**: The material has temperature class T120. A higher number is also allowed, but not lower.
- 3 **P1**: The material falls into pressure class P1. H1 is also allowed.
- 4 **W**: The material is suitable for draining condensation water (W='wet'). D is not allowed (D='dry').
- 5 **E**: The material falls into fire resistance class E. Class A to D are also allowed, F is not allowed. Only applicable to plastic.

Tab.13 Overview of material properties

Version	Flue gas outlet		Air supply	
	Material	Material properties	Material	Material properties
Single-wall, rigid	<ul style="list-style-type: none"> • Plastic⁽¹⁾ • Stainless steel⁽²⁾ • Thick-walled, aluminium⁽²⁾ 	<ul style="list-style-type: none"> • With CE marking • Temperature class T120 or higher • Condensate class W (wet) • Pressure class P1 or H1 • Fire resistance class E or better⁽³⁾ 	<ul style="list-style-type: none"> • Plastic • Stainless steel • Aluminium 	<ul style="list-style-type: none"> • With CE marking • Pressure class P1 or H1 • Fire resistance class E or better⁽³⁾
<p>(1) According to EN 14471. (2) According to EN 1856. (3) According to EN 13501-1.</p>				

4.6.3 Dimensions of flue gas outlet pipe



Danger

Flue gas leakage

Chance of CO poisoning.

- Only connect pipes to the flue gas adapter that satisfy the dimension requirements.

Fig.9 Dimensions of parallel connection

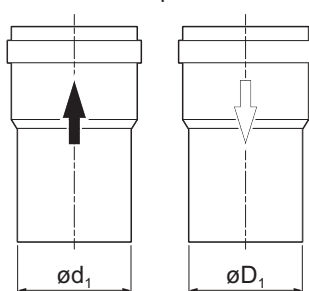

AD-3000963-01

d_1 External dimensions of flue gas outlet pipe

D_1 External dimensions of air supply pipe

Tab.14 Dimensions of pipe

	d_1 (min-max)	D_1 (min-max)
80/80 mm	79.3 – 80.3 mm	79.3 – 80.3 mm
100/100 mm	99.3 – 100.3 mm	99.3 – 100.3 mm

Fig.10 Dimensions of concentric connection

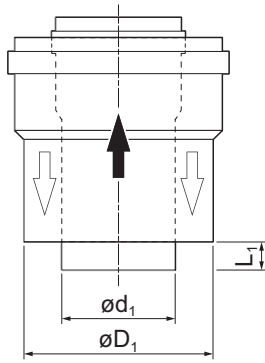

AD-3000962-01

- d_1 External dimensions of flue gas outlet pipe
- D_1 External dimensions of air supply pipe
- L_1 Length difference between flue gas outlet pipe and air supply pipe

Tab.15 Dimensions of pipe

	d_1 (min-max)	D_1 (min-max)	$L_1^{(1)}$ (min-max)
80/125 mm	79.3 – 80.3 mm	124 – 125.5 mm	0 – 15 mm
100/150 mm	99.3 – 100.3 mm	149 – 151 mm	0 – 15 mm

(1) Shorten the inner pipe if the length difference is too great.

4.6.4 Length of the flue and air supply pipes

The maximum length of the flue and air supply vary per appliance type. Consult the relevant chapter for the correct lengths.

- If a boiler is not compatible with a specific flue system or diameter, it is indicated with "-" in the table.
- When using bends, the maximum flue length (L) must be shortened according to the reduction table.
- Use approved flue reducers for adaptation to another diameter.

■ Maximum flue lengths for B₂₃, B_{23P}, B₃₃

Fig.11 Flue system length

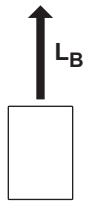

AD-3002009-01

- L_B Length from the flue gas connection up to the terminal.
- Calculation: $L = L_B$

Tab.16 Maximum length (L)

Diameter ⁽¹⁾	80 mm ⁽²⁾	80 mm ⁽³⁾	100 mm ⁽²⁾	100 mm ⁽³⁾
AMC PRO EVO 35	29 m	40 m	40 m ⁽¹⁾	40 m ⁽¹⁾
AMC PRO EVO 45	39 m	40 m ⁽¹⁾	40 m ⁽¹⁾	40 m ⁽¹⁾
AMC PRO EVO 65	11 m	23 m	26 m	40 m ⁽¹⁾
AMC PRO EVO 90	10 m	21 m	24 m	40 m
AMC PRO EVO 115	8 m	17 m	19 m	39 m

(1) While maintaining the maximum length, additional 5 times 90° or 10 times 45° bends can be used (indicated for each boiler type and diameter).
 (2) Maximum length (L) at nominal load.
 (3) Maximum length (L) at 10% load reduction.

■ Maximum flue lengths for C_{13(X)}, C_{33(X)}, C_{63(X)}, C_{93(X)}

Fig.12 Flue system length (Parallel)

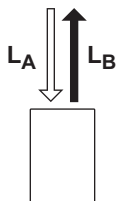

AD-3002010-01

- L_A Length from the terminal up to the air inlet connection.
- L_B Length from the flue gas connection up to the terminal.
- Calculation: $L = L_A + L_B$

Tab.17 Maximum length (L)

Diameter ⁽¹⁾	80 mm ⁽²⁾	80 mm ⁽³⁾	100 mm ⁽²⁾	100 mm ⁽³⁾
AMC PRO EVO 35	24 m	40 m	40 m ⁽¹⁾	40 m ⁽¹⁾
AMC PRO EVO 45	34 m	40 m ⁽¹⁾	40 m ⁽¹⁾	40 m ⁽¹⁾
AMC PRO EVO 65	2 m	16 m	20 m	40 m

Diameter ⁽¹⁾	80 mm ⁽²⁾	80 mm ⁽³⁾	100 mm ⁽²⁾	100 mm ⁽³⁾
AMC PRO EVO 90	-	14 m	16 m	40 m
AMC PRO EVO 115	-	8 m	12 m	34 m

(1) While maintaining the maximum length, additional 5 times 90° or 10 times 45° bends can be used (indicated for each boiler type and diameter).
(2) Maximum length (L) at nominal load.
(3) Maximum length (L) at 10% load reduction.

Fig.13 Flue system length (Concentric)

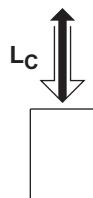

L_C Length from the air inlet connection and flue gas connection up to the terminal.

Calculation: $L = L_C$

AD-3002011-01

Tab.18 Maximum length (L)

Diameter ⁽¹⁾	80/125 mm ⁽²⁾	80/125 mm ⁽³⁾	100/150 mm ⁽²⁾	100/150 mm ⁽³⁾
AMC PRO EVO 35	18 m	20 m ⁽¹⁾	20 m ⁽¹⁾	20 m ⁽¹⁾
AMC PRO EVO 45	20 m	20 m ⁽¹⁾	20 m ⁽¹⁾	20 m ⁽¹⁾
AMC PRO EVO 65	4 m	13 m	18 m	20 m ⁽¹⁾
AMC PRO EVO 90	4 m	12 m	17 m	20 m ⁽¹⁾
AMC PRO EVO 115	-	8 m	13 m	20 m ⁽¹⁾

(1) While maintaining the maximum length, additional 5 times 90° or 10 times 45° bends can be used (indicated for each boiler type and diameter).
(2) Maximum length (L) at nominal load.
(3) Maximum length (L) at 10% load reduction.

■ Maximum flue lengths for C_{43P}

Fig.14 Flue system length

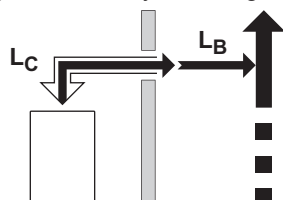

L_B Maximum of 2 m extra length of the flue can be added up to the common shared flue system.

L_C Length from the air inlet connection and flue gas connection up to the common shared flue system.

Calculation: $L = L_C$

AD-3002012-01

Tab.19 Maximum length (L)

Diameter ⁽¹⁾	80/125 mm ⁽²⁾	80/125 mm ⁽³⁾
AMC PRO EVO 35	13 m	20 m ⁽¹⁾
AMC PRO EVO 45	20 m	20 m ⁽¹⁾
AMC PRO EVO 65	4 m	13 m
AMC PRO EVO 90	4 m	13 m
AMC PRO EVO 115	4 m	10 m

(1) While maintaining the maximum length, additional 5 times 90° or 10 times 45° bends can be used (indicated for each boiler type and diameter).
(2) Maximum length (L) at nominal load.
(3) Maximum length (L) at 10% load reduction.

■ **Maximum flue lengths for C₅₃**

Fig.15 Flue system length

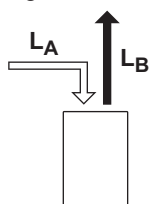

L_A Length from the terminal up to the air inlet connection.
L_B Length from the flue gas connection up to the terminal.
 Calculation: $L = L_A + L_B$

i Important
 The maximum permitted height difference between the air inlet and the roof terminal is 36 m.

AD-3002013-01

Tab.20 Maximum length (L)

Diameter ⁽¹⁾	80 mm ⁽²⁾	80 mm ⁽³⁾	100 mm ⁽²⁾	100 mm ⁽³⁾
AMC PRO EVO 35	16 m	40 m	40 m	40 m ⁽¹⁾
AMC PRO EVO 45	29 m	40 m ⁽¹⁾	40 m ⁽¹⁾	40 m ⁽¹⁾
AMC PRO EVO 65	5 m	17 m	16 m	40 m
AMC PRO EVO 90	-	17 m	17 m	40 m
AMC PRO EVO 115	-	13 m	14 m	34 m

(1) While maintaining the maximum length, additional 5 times 90° or 10 times 45° bends can be used (indicated for each boiler type and diameter).
 (2) Maximum length (L) at nominal load.
 (3) Maximum length (L) at 10% load reduction.

■ **Reduction table**

Tab.21 Pipe reduction for each bend - radius 1/2D (parallel)

Diameter	80 mm	100 mm
	1,2 m	1,4 m
	4,0 m	4,9 m

Tab.22 Pipe reduction for each bend - radius 1/2D (concentric)

Diameter	80/125 mm	100/150 mm
	1,0 m	1,0 m
	2,0 m	2,0 m

4.6.5 Additional guidelines

■ **Installation**

- For installing the flue gas outlet and air supply materials, refer to the instructions of the manufacturer of the material.
- After installation, check at least all flue gas outlet and air supply parts for tightness.
- Install the flue gas outlet pipe towards the boiler with a sufficient gradient (at least 50 mm per metre).
- Install a sufficient condensate collector and discharge at least 1 m before the outlet of the boiler.
- The bends used must be larger than 90° to guarantee the gradient and a good seal on the lip rings.
- For Italy: The flue gas outlet must be carefully positioned so that the flue gases are dispersed correctly, in accordance with UNI - CIG 7129.

■ Condensation

- Direct connection of the flue gas outlet to structural ducts is not permitted because of condensation.
- If condensate from a plastic or stainless steel pipe section can flow back to an aluminium part in the flue gas outlet, this condensate must be discharged via a trap before it reaches the aluminium.
- Newly installed aluminium flue gas pipes with longer lengths can produce relatively larger quantities of corrosion products. Also casting sand and processing metal chips from new boilers can fill the boiler trap on short term after installation. Check and clean the trap more often for these reasons.

4.7 Requirements for the electrical connections

- Establish the electrical connections in accordance with all current local and national regulations and standards.
- Electrical connections must only be made by qualified installers, and only while the power supply is disconnected.
- The appliance is completely pre-wired. Never change the internal connections of the control panel.
- Always connect the appliance to a well-earthed installation.
- If the power cord is permanently connected, you must always install a main bipolar switch with an opening gap of at least 3 mm (EN 60335-1).
- For France: The standard NF C 15,100.
- For Italy: The standard CEI.
- The wiring must comply with the instructions in the electrical diagrams.
- Follow the recommendations in this manual.
- Separate the sensor cables from the 230 V cables
- Outside the appliance: Use 2 cables spaced at least 10 cm apart.

Make sure the following requirements are met when connecting the cables to the PCB connectors:

Tab.23 PCB connectors

Wire cross section	Stripping length	Tightening torque
solid wire: 0.14 – 4.0 mm ² (AWG 26 – 12) stranded wire: 0.14 – 2.5 mm ² (AWG 26 – 14) stranded wire with ferrule: 0.25 – 2.5 mm ² (AWG 24 – 14)	8 mm	0.5 N·m

4.8 Water quality and water treatment



Notice

Water quality

Damage to the product.

Warranty void.

- Make sure the water quality requirements are fulfilled.

For this appliance, the quality of the heating water must comply with all requirements as listed in **VDI 2035**. If water quality requirements for other components in the system are stated, the most stringent requirements apply.

If water quality is not met, consult a specialist.

Tab.24 Water quality requirements according to VDI 2035

Heat exchanger material	Unit	Aluminium
Degree of acidity at 25 °C	pH	6.5 - 8.5
Electrical conductivity at 25 °C (for low saline water)	µS/cm	≤ 100
Electrical conductivity at 25 °C (for saline water)	µS/cm	100 - 1500
Oxygen (for low saline water)	mg/l	≤ 0.1
Oxygen (for saline water)	mg/l	≤ 0.02
Sum of alkaline earth metals	mmol/l	≤ 0.02

4.9 Installation examples

4.9.1 Symbols used

The diagrams consist of the following symbols:

4 Before installation

Fig.16 Controllers

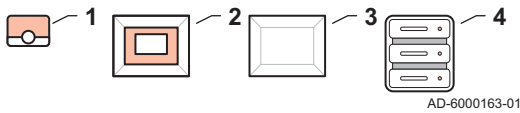

AD-6000163-01

- 1 Room unit (thermostat) (R)
- 2 Controller (R)
- 3 Wall box (R)
- 4 Building management system (R)

Fig.17 Producers

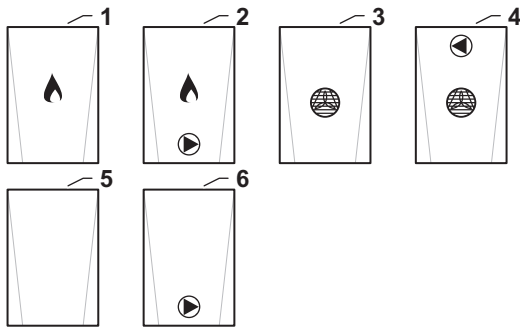

AD-6000164-01

- 1 Gas boiler (A)
- 2 Gas boiler with internal pump (A)
- 3 Heat pump (A)
- 4 Heat pump with internal pump (A)
- 5 Undefined producer (A)
- 6 Undefined producer with internal pump (A)

Fig.18 Consumers

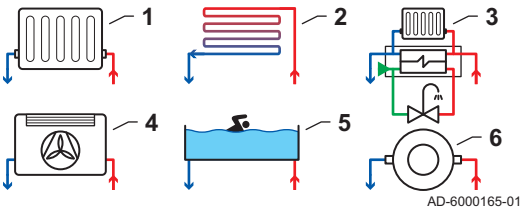

AD-6000165-01

- 1 Radiator
- 2 Underfloor heating
- 3 Heat interface unit
- 4 Fan convector
- 5 Swimming pool
- 6 Process heat (generic heating)

Fig.19 Domestic hot water

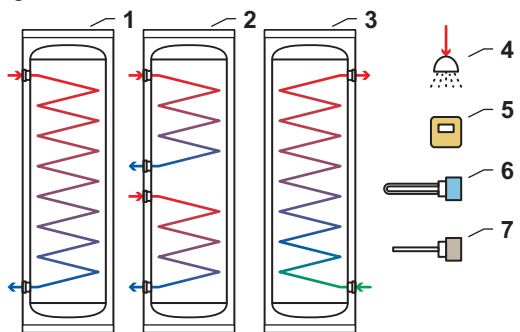

AD-6000166-01

- 1 Domestic hot water cylinder with single coil
- 2 Domestic hot water cylinder with double coil
- 3 Domestic hot water cylinder with hygienic coil
- 4 Shower
- 5 Internal control sensor (S)
- 6 Immersion heater (B)
- 7 Sacrificial anode (D)

Fig.20 Hydraulic separation

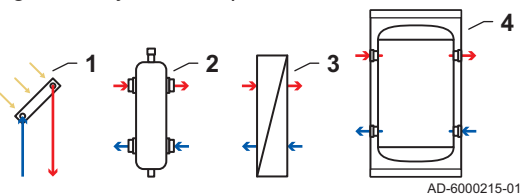

AD-6000215-01

- 1 Solar collector
- 2 Low loss header (H)
- 3 Plate heat exchanger (H)
- 4 Buffer tank (H)

Fig.21 Components

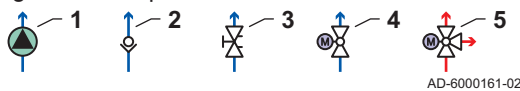

AD-6000161-02

- 1 Pump (P)
- 2 Non-return valve
- 3 Balancing valve
- 4 Hydraulic valve (V)
- 5 Diverter valve (V)

Fig.22 Sensors

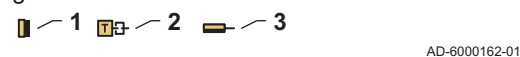

AD-6000162-01

- 1 Outdoor temperature sensor (S)
- 2 Temperature sensor (S)
- 3 Safety temperature limiter (S)

Fig.23 Tubing

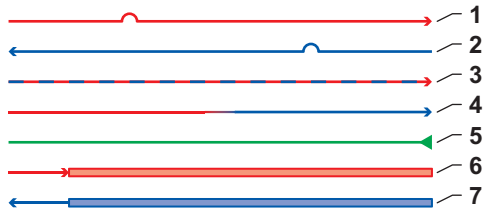

AD-6000160-01

- 1 Flow pipe
- 2 Return pipe
- 3 Heating or cooling pipe
- 4 Flow to return pipe
- 5 Water supply
- 6 Flow collector pipe
- 7 Return collector pipe

4.9.2 Single boiler - 2 circuits (Direct circuit, Underfloor mixing circuit) - Domestic hot water cylinder with two sensors

Fig.24 Diagram and components - 6000254

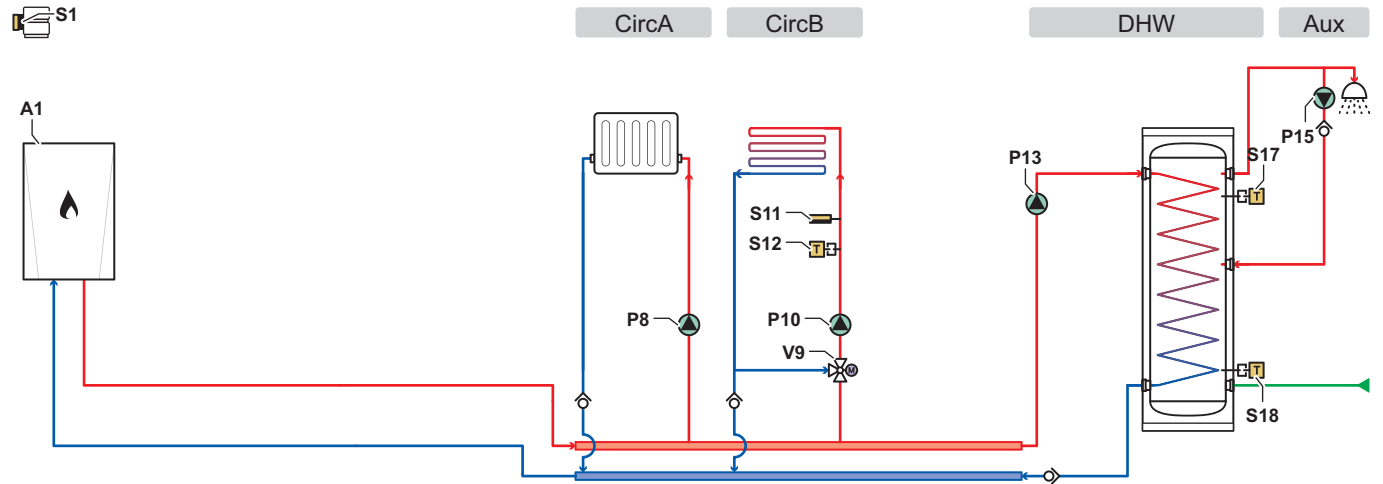

AD-6000254-01

- CircA** Circuit A (Direct circuit)
- CircB** Circuit B (Underfloor mixing circuit)
- DHW** DHW circuit (Domestic hot water cylinder with two sensors)
- Aux** Auxiliary circuit (Domestic hot water loop)
- A1** Boiler with SCB-10 and AD249
- P8** Circuit A pump
- P10** Circuit B pump
- P13** DHW charge pump
- P15** DHW circulation loop pump
- S1** Outdoor temperature sensor
- S11** Circuit B safety temperature limiter
- S12** Circuit B flow temperature sensor
- S17** DHW cylinder top temperature sensor
- S18** DHW cylinder bottom temperature sensor
- V9** Circuit B mixing valve

Fig.25 Electrical connections - Boiler A1

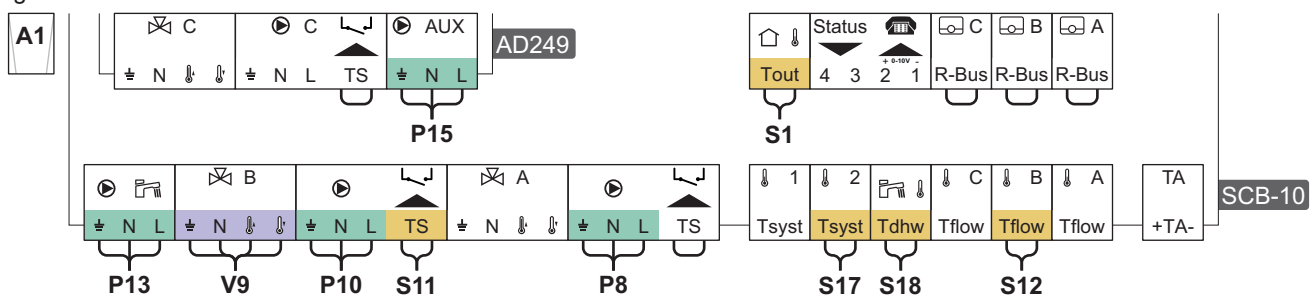

AD-6000107-01

Tab.25 Parameter list

Code ⁽¹⁾	Display text	Set on device	Set to
CP020	Zone Function	SCB-10	1 = Direct
CP021	Zone Function	SCB-10	2 = Mixing Circuit
CP022	Zone Function	SCB-10	10 = DHW Layered
CP023	Zone Function	SCB-10	0 = Disable
CP024	Zone Function	SCB-10	0 = Disable
CP294	ConfigZonePumpOut	SCB-10	8 = DHW looping
EP037	Sensor input config	SCB-10	2 = DHW tank top

(1) Use this parameter code with the search function (Search datapoints) of the control panel to access the parameter.

4.9.3 Single boiler - 3 circuits (Underfloor mixing circuit, Fan coil unit (direct), Swimming pool (direct)) - Domestic hot water cylinder with two sensors

Fig.26 Diagram and components - 6000255

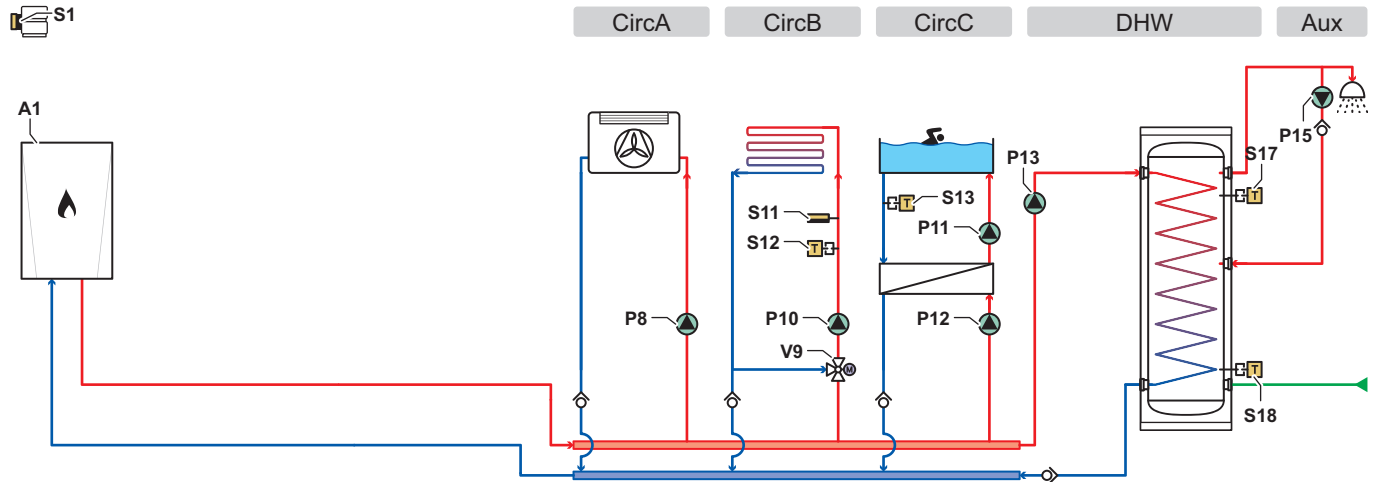

AD-6000255-01

- CircA** Circuit A (Underfloor mixing circuit)
- CircB** Circuit B (Fan coil unit (direct))
- CircC** Circuit C (Swimming pool (direct))
- DHW** DHW circuit (Domestic hot water cylinder with two sensors)
- Aux** Auxiliary circuit (Domestic hot water loop)
- A1** Boiler with SCB-10 and AD249
- P8** Circuit A pump
- P10** Circuit B pump
- P11** Swimming pool pump
- P12** Circuit C pump
- P13** DHW charge pump
- P15** DHW circulation loop pump
- S1** Outdoor temperature sensor
- S11** Circuit B safety temperature limiter
- S12** Circuit B flow temperature sensor
- S13** Circuit C return temperature sensor
- S17** DHW cylinder top temperature sensor
- S18** DHW cylinder bottom temperature sensor
- V9** Circuit B mixing valve

Fig.27 Electrical connections - Boiler A1

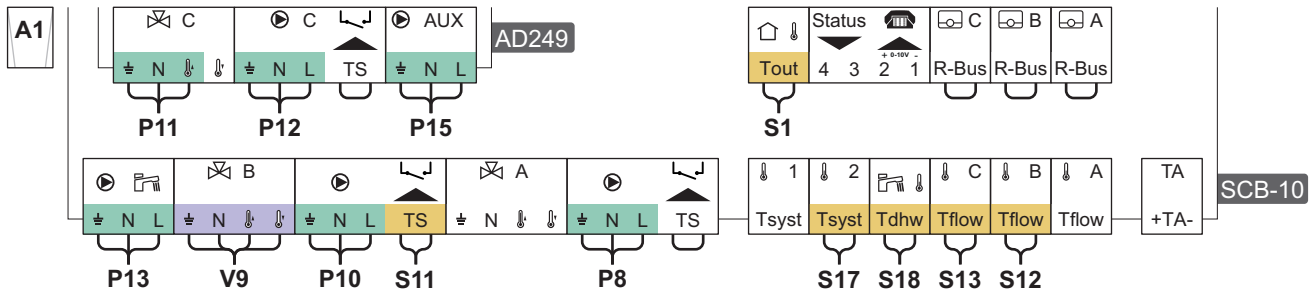

AD-6000109-01

Tab.26 Parameter list

Code ⁽¹⁾	Display text	Set on device	Set to
CP020	Zone Function	SCB-10	5 = Fan Convector
CP021	Zone Function	SCB-10	2 = Mixing Circuit
CP022	Zone Function	SCB-10	10 = DHW Layered
CP023	Zone Function	SCB-10	3 = Swimming pool
CP024	Zone Function	SCB-10	0 = Disable
CP294	ConfigZonePumpOut	SCB-10	8 = DHW looping
EP037	Sensor input config	SCB-10	2 = DHW tank top

(1) Use this parameter code with the search function (Search datapoints) of the control panel to access the parameter.

4.9.4 Cascade of two boilers - 3 circuits (Mixing circuit, Mixing circuit, Mixing circuit) - Domestic hot water cylinder with two sensors

Fig.28 Diagram and components - 6000256

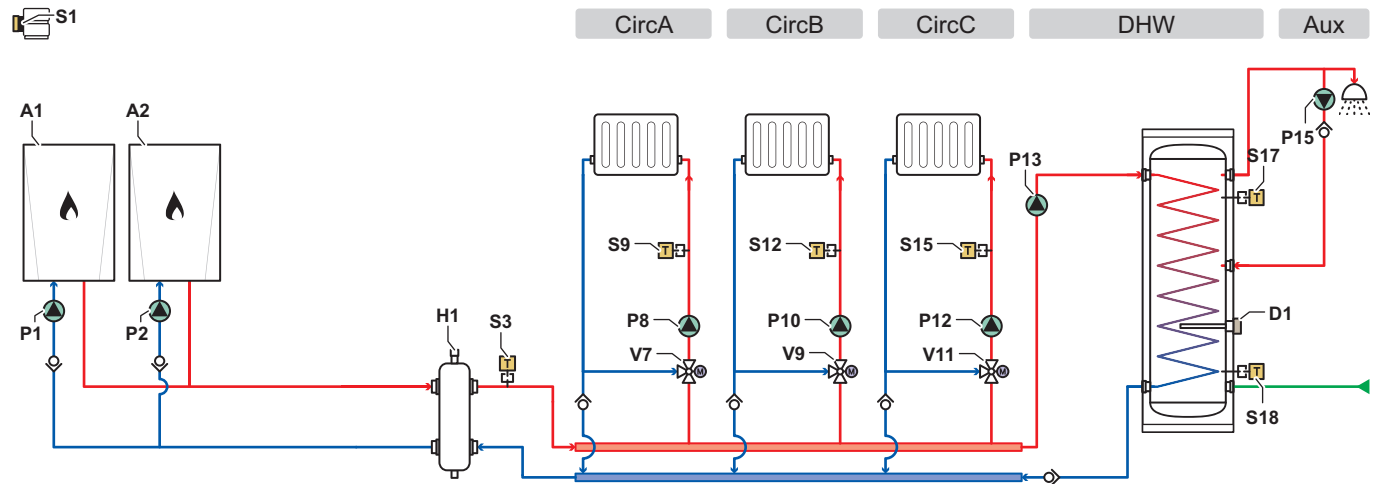

AD-6000256-01

- CircA** Circuit A (Mixing circuit)
- CircB** Circuit B (Mixing circuit)
- CircC** Circuit C (Mixing circuit)
- DHW** DHW circuit (Domestic hot water cylinder with two sensors)
- Aux** Auxiliary circuit (Domestic hot water loop)
- A1** Lead boiler with CB-23, SCB-10 and AD249
- A2** Lag boiler with CB-23 and SCB-10
- D1** Sacrificial anode
- H1** Low loss header
- P1** Appliance A1 pump
- P2** Appliance A2 pump
- P8** Circuit A pump
- P10** Circuit B pump
- P12** Circuit C pump
- P13** DHW charge pump
- P15** DHW circulation loop pump
- S1** Outdoor temperature sensor
- S3** Low loss header flow temperature sensor
- S9** Circuit A flow temperature sensor
- S12** Circuit B flow temperature sensor
- S15** Circuit C flow temperature sensor
- S17** DHW cylinder top temperature sensor
- S18** DHW cylinder bottom temperature sensor
- V7** Circuit A mixing valve
- V9** Circuit B mixing valve
- V11** Circuit C mixing valve

Fig.29 Electrical connections - Lead boiler A1

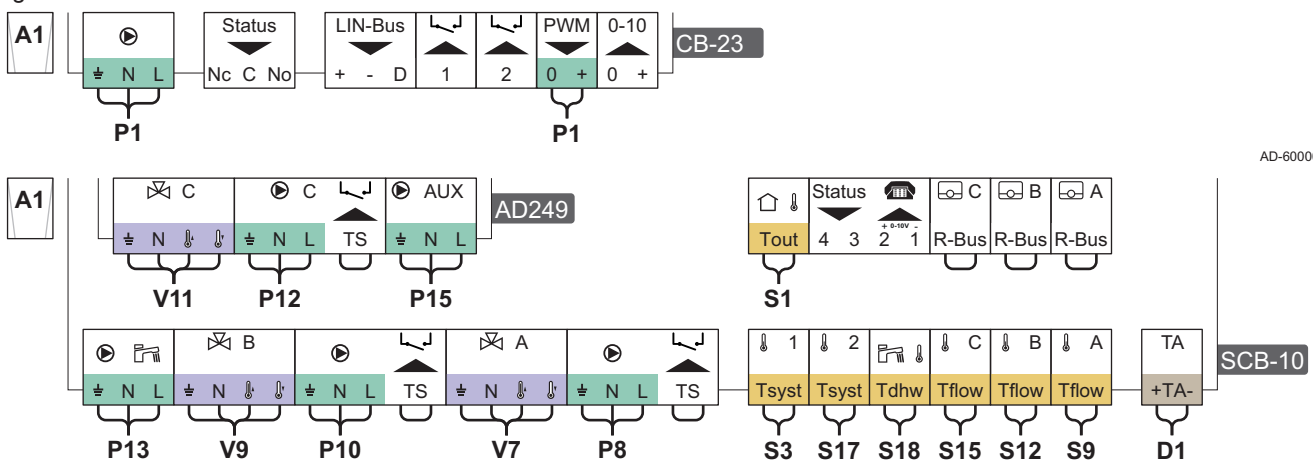

AD-6000073-01

AD-6000259-01

Fig.30 Electrical connections - Lag boiler A2

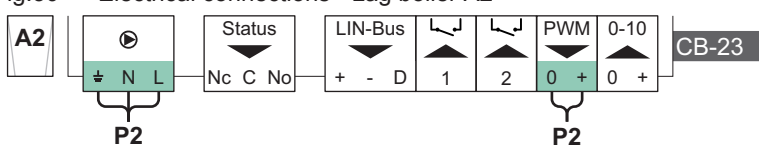

AD-6000074-01

Fig.31 S-Bus connections - Lead boiler A1 to Lag boiler A2

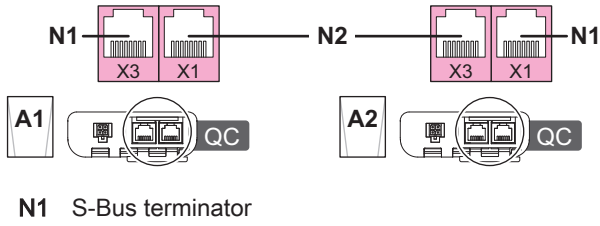

AD-6000157-01

N1 S-Bus terminator

N2 S-Bus connection between appliances

Tab.27 Parameter list

Code ⁽¹⁾	Display text	Set on device	Set to
CP020	Zone Function	SCB-10	2 = Mixing Circuit
CP021	Zone Function	SCB-10	2 = Mixing Circuit
CP022	Zone Function	SCB-10	10 = DHW Layered
CP023	Zone Function	SCB-10	2 = Mixing Circuit
CP024	Zone Function	SCB-10	8 = Time Program
CP294	ConfigZonePumpOut	SCB-10	8 = DHW looping
EP037	Sensor input config	SCB-10	2 = DHW tank top

(1) Use this parameter code with the search function (Search datapoints) of the control panel to access the parameter.

5 Installation

5.1 Positioning the boiler

Fig.32 Transporting the boiler

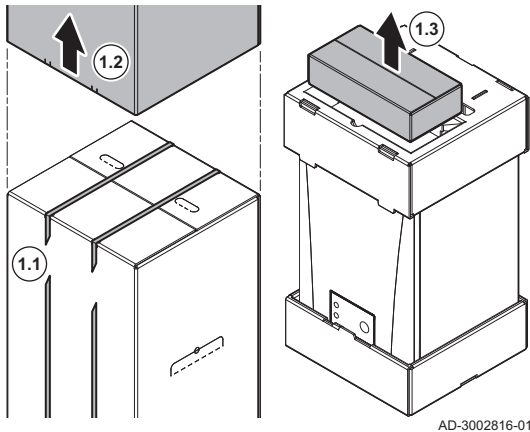

AD-3002816-01

1. Transport the boiler to the installation location:

- 1.1. Remove the retaining straps.
- 1.2. Remove the box.
- 1.3. Remove the box with additional parts.



This box contains the wall bracket with fasteners and the mounting template for the next steps.

Fig.33 Installing the wall bracket

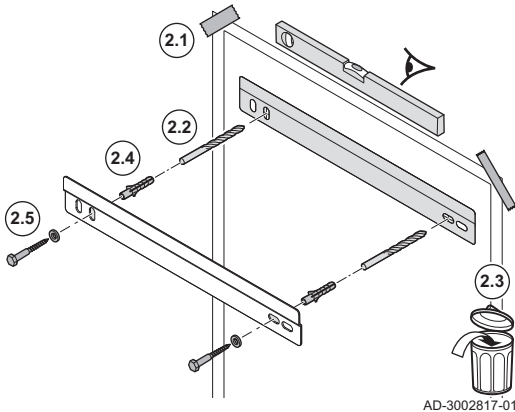

AD-3002817-01

2. Install the wall bracket:

- 2.1. Attach the mounting template of the boiler to the wall using adhesive tape.



Important

Make sure the mounting template is hanging perfectly horizontal.

- 2.2. Drill 2 holes of Ø 10 mm at the marked spots on the template.



The extra holes in the bracket can be used if one of the holes is not suitable for correct fastening.

- 2.3. Remove the mounting template.
- 2.4. Fit the plugs.
- 2.5. Attach the wall bracket to the wall with the screws and washers.

Fig.34 Positioning the boiler

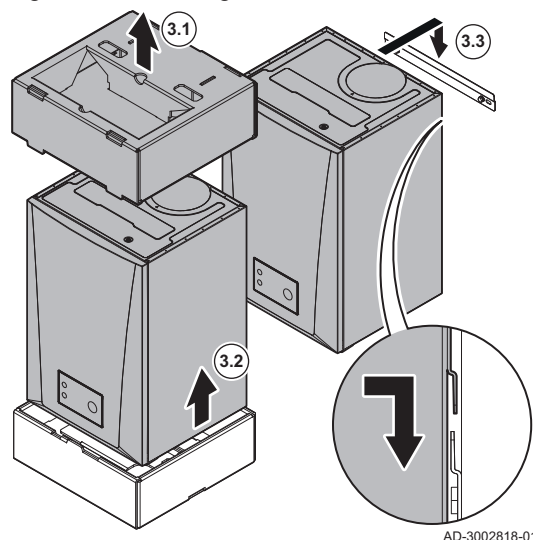

3. Lift and position the boiler:
 - 3.1. Remove the other pieces of packaging.
 - 3.2. Lift the boiler out of the lower tray.
 - 3.3. Hang the boiler on the wall bracket.

💡 For the desired position of the boiler, you can move the boiler 30 mm to the left or right from the centre of the wall bracket.

Fig.35 Routing the power cable

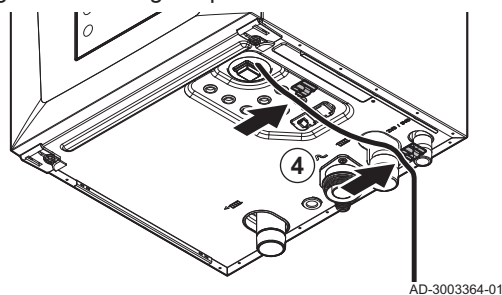

4. Route the power cable through the clips on the bottom of the boiler.

5.2 Flushing the system

Before a new appliance can be connected to a system, the entire system must be thoroughly cleaned by flushing it. The flushing will remove residue and dirt from the installation process. If applicable:

- Flush the heating system with at least 3 times the volume of the system.
- Flush the domestic hot water pipes with at least 20 times the volume of the pipes.

5.3 Connecting the heating system

Fig.36 Connecting the heating system

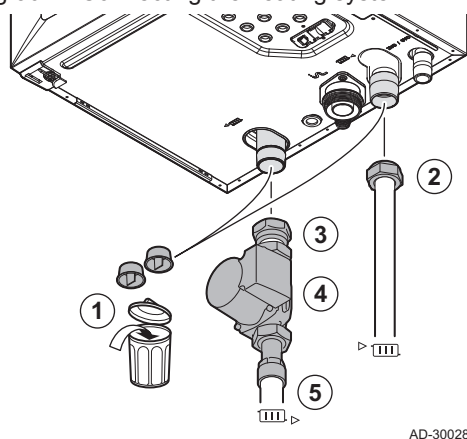

1. Remove the dust caps from the flow and return connections.
2. Fit the system flow pipe to the flow connection.
3. Fit the system return pipe to the return connection.
4. Fit a pump in the system return pipe.
5. Fit the system return pipe to the pump.

5.4 Connecting the discharge

Fig.37 Connecting the discharge

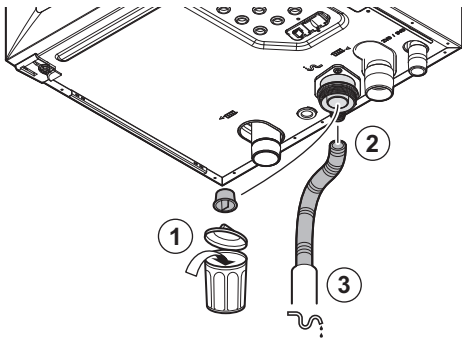

AD-3002820-01

1. Remove the dust cap from the condensate connection
2. Fit the flexible condensate drain hose on the condensate outlet.
3. Lead this drain hose to a plastic drain pipe of Ø 32 mm or larger, terminating in the drain.

5.5 Connecting the gas pipe

Fig.38 Connecting the gas pipe

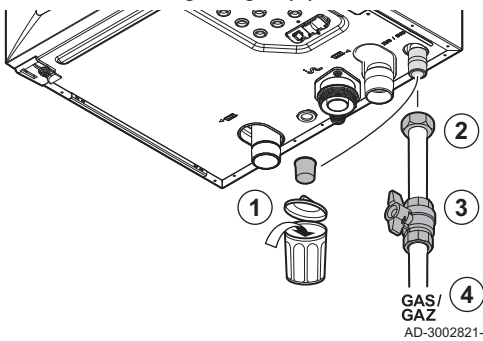

AD-3002821-01

1. Remove the dust cap from the gas connection.
2. Fit the gas supply pipe to the gas connection.
3. Fit a gas cock near the boiler.
4. Fit the gas supply pipe to the gas cock.

5.6 Connecting the air inlet and flue gas outlet

Fig.39 Connecting the air inlet and flue gas outlet

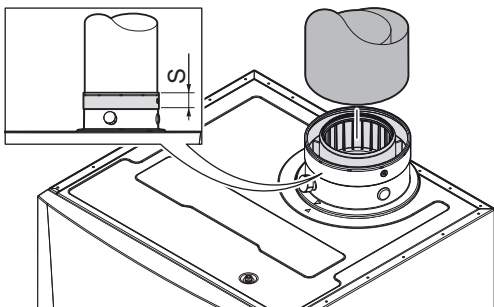

AD-3002823-01

1. Connect the air inlet and flue gas outlet to the boiler.
S Insertion depth 25 mm
2. Fit the subsequent flue gas outlet pipes in accordance with the manufacturer's instructions.

Danger
Flue gas leakage
 Chance of CO poisoning.

- The pipes must not be resting on the boiler.
- Fit the horizontal parts sloping down towards the boiler, with a slope of 50 mm per metre.

5.7 Mounting the outdoor temperature sensor

Place the outdoor temperature sensor in a position that covers the following characteristics:

- On a façade of the area to be heated, on the north if possible.
- Half way up the wall of the area to be heated.
- Under the influence of changes in the weather.
- Protected from direct sunlight.
- Easy to access.

Fig.40 Advised positions

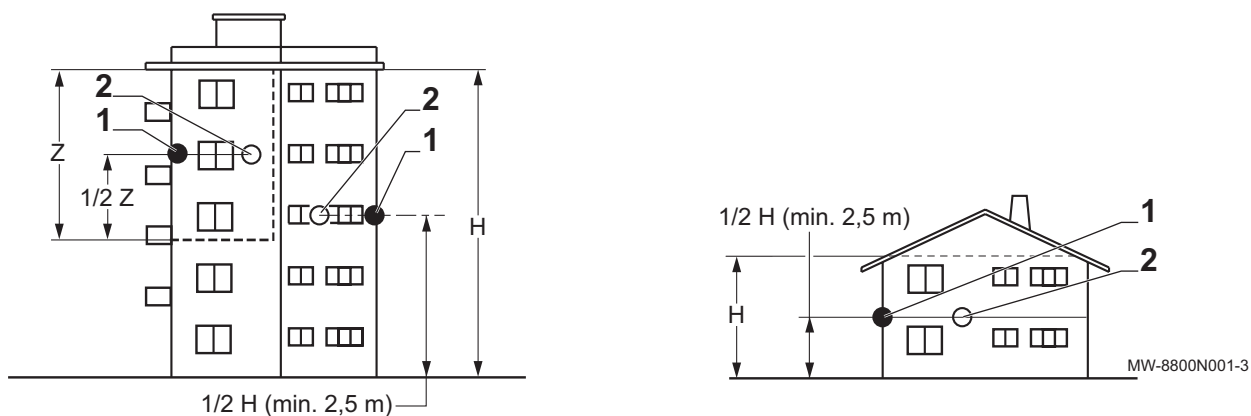

- 1 Optimum location
2 Possible location

- H Inhabited height controlled by the sensor
Z Inhabited area controlled by the sensor

Avoid placing the outdoor temperature sensor in a position with the following characteristics:

- Masked by part of the building (balcony, roof, etc.).
- Close to a disruptive heat source (sun, chimney, ventilation grid, etc.).

Fig.41 Positions to be avoided

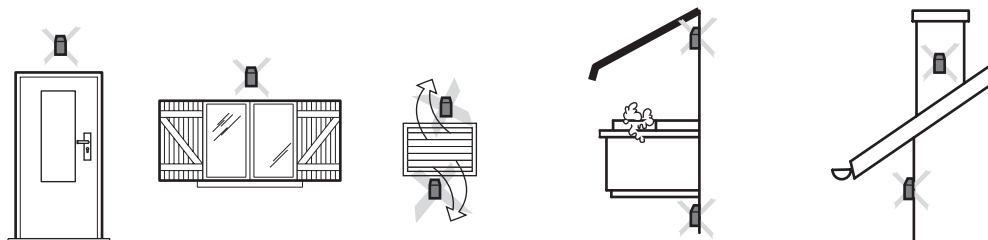
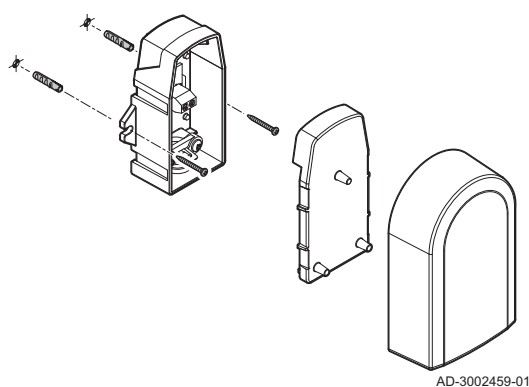

Fig.42 Mount the outdoor temperature sensor



1. Drill two holes with a diameter of 6 mm.
2. Put the two plugs in place.
3. Secure the sensor using two screws.
4. Connect the cable to the outdoor temperature sensor.

5.8 Electrical connections



See also
Opening the boiler, page 77

5.8.1 Quick connect location

The Quick connect has L-Bus and S-Bus sockets for external connections. You can easily connect external devices and other appliances without opening the boiler.

Fig.43 Quick connect location

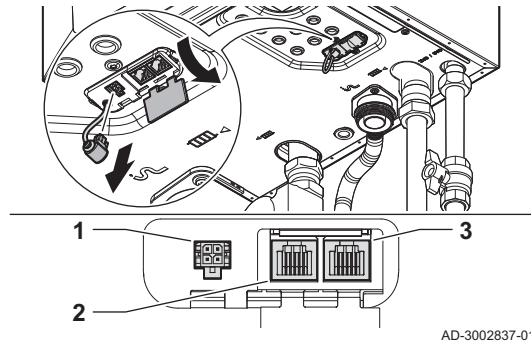

- 1 L-Bus socket for a 4 pin Molex Micro-Fit plug
- 2 S-Bus socket for a RJ12 plug
- 3 S-Bus socket for a RJ12 plug



Warning

Cable quality

Chance of electrical fire

- Only use original cables that are either available as an accessory, or are provided with an accessory.

Fig.44 L-Bus connector



AD-3003126-01

■ **Quick connect L-Bus connector**

You can connect an external device to the connector. This extends the local bus to a wall box or gateway. To use this connector, remove the L-Bus terminator.



- The L-Bus terminator has a retaining latch. Press the latch to remove the terminator.
- When you disconnect the external device, reconnect the L-Bus terminator.

■ **Quick connect S-Bus connectors**

You can build a cascade of boilers with the connectors. Use the S-Bus connectors to link up to 8 boilers in a cascade system.

You can link the boilers to create the cascade system:

Fig.45 S-Bus connectors (RJ12)



AD-3003127-01

Fig.46 Cascade system

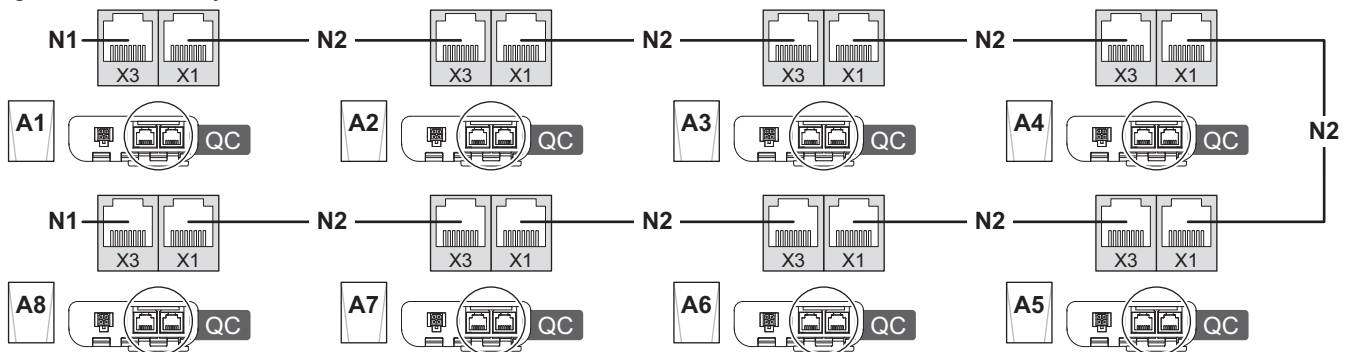

AD-3003417-01

- A1 Lead boiler with Quick connect
- A2 Lag boiler with Quick connect
- A3 Lag boiler with Quick connect
- A4 Lag boiler with Quick connect
- A5 Lag boiler with Quick connect

- A6 Lag boiler with Quick connect
- A7 Lag boiler with Quick connect
- A8 Lag boiler with Quick connect
- N1 S-Bus terminator
- N2 S-Bus connection between appliances

5.8.2 PCB locations

This illustration shows the location for each PCB. Both factory-fitted and optional PCBs are shown.

Fig.47 PCB locations

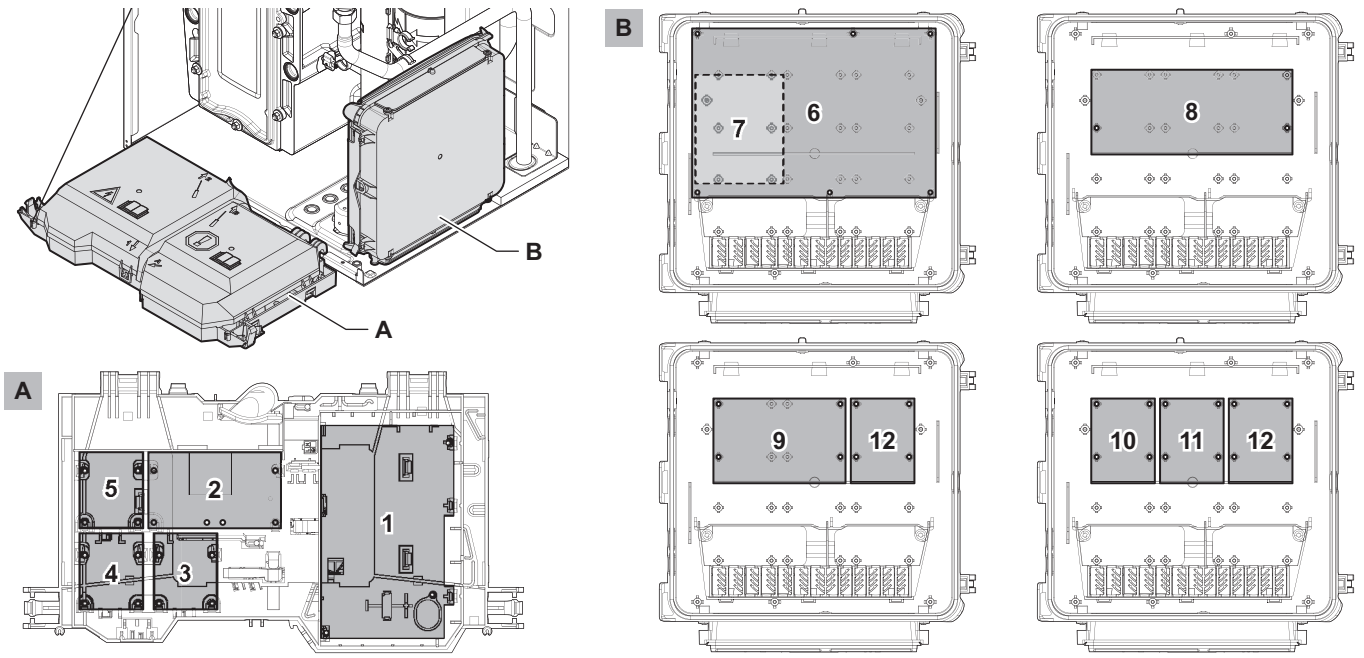

AD-3002824-01

Tab.28 Primary and optional locations

Device	Primary location	Location option
CU-GH22	1	-
CB-23	2	-
SCB-09 (optional)	5	3 / 4
SCB-10	6	-
AD249 (optional)	7	-
GTW-08 Modbus (optional)	3	4
GTW-21 BACNet (optional)	3	4

5.8.3 Access to the control box

Fig.48 Tilt the control box forward

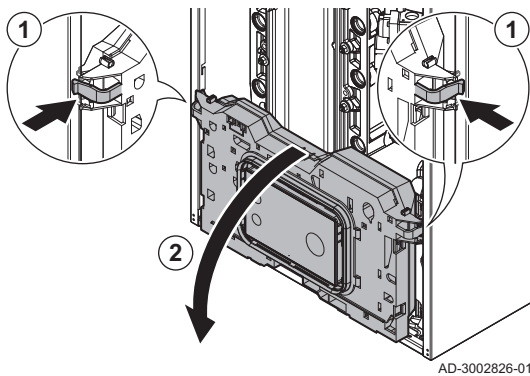

AD-3002826-01

1. Press the clips on the sides of the control box inwards slightly.
2. Tilt the control box forwards.

Fig.49 Lift the cover

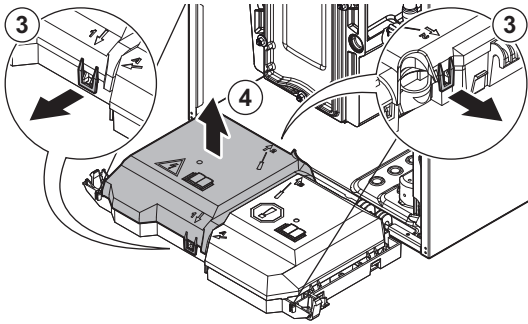

AD-3002827-01

3. Gently pull forward the clips on the front side $\uparrow\downarrow$ and back side $\uparrow\downarrow$ of the cover simultaneously.
4. Lift the cover.
⇒ The connectors on the connection board are now accessible.



You can also access the control unit. Repeat the steps with the clips on the front side $\uparrow\downarrow$ and back side $\uparrow\downarrow$ of the other cover.

Fig.50 Cable routing

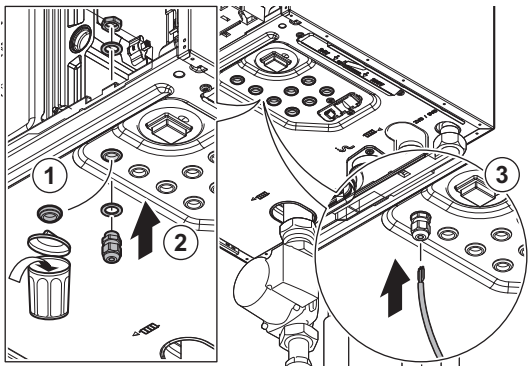

AD-3003122-01

■ Cable routing to the control box

The boiler has eight cable gland positions. You can use the cable glands to route cables to the control box.

1. Select the desired cable gland position and remove the grommet.
2. Mount the cable gland.
3. Route the cable to the control box.

Fig.51 Connecting the cable

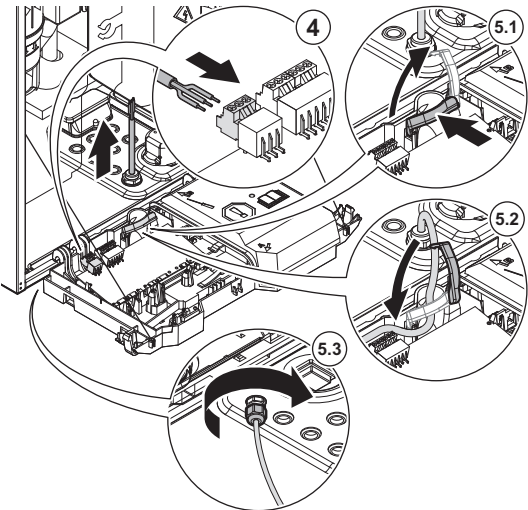

AD-3003123-02

4. Connect the cable to the connection PCB.
5. Secure the cable:
 - 5.1. Open the clip in the control box.



To open the clip: Push in the middle and rotate.

- 5.2. Close the clip in the control box.
- 5.3. Tighten the sealing nut on the cable gland.

5.8.4 Access to the expansion box

Fig.52 Access to the expansion box

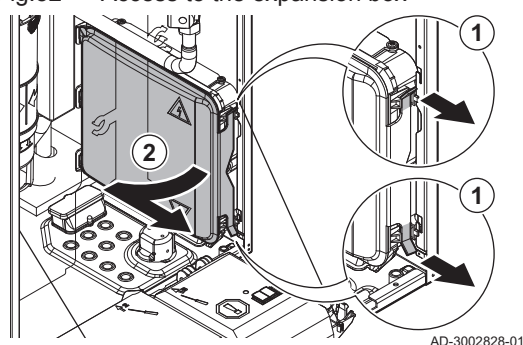

AD-3002828-01

1. Gently pull forward the clips on the front side of the cover.
2. Remove the cover.

■ Cable routing to the expansion box

The expansion box has two possible openings for cables. You can use these openings to route cables to the expansion box.

1. Cut the rubber seal in the desired opening.

- A Cable opening for low voltage cables (≤ 24 V)
- B Cable opening for power cables (≈ 230 V)

2. Route the cable to the expansion box.

Fig.53 Cable routing

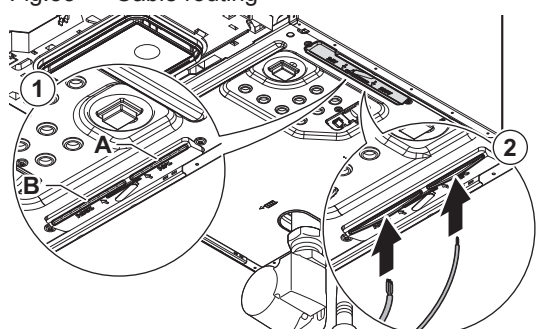

AD-3003103-01

Fig.54 Connecting the cable

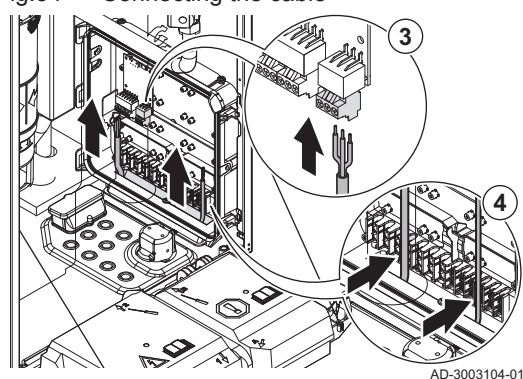

AD-3003104-01

3. Connect the cable to the expansion PCB.
4. Secure the cable with the clips in the expansion box.

5.8.5 Introduction to the CB-23 connection PCB

The AMC PRO EVO boiler is equipped with the new generation connection PCB. The **CB-23** offers more connection options and reduces the need for expansion PCBs.

Tab.29 Available options



Options	Description
Configurable input and output	This option makes it possible to configure the input and output connectors. Depending on the desired system, you can select and combine the available configurations. You can change the behaviour of the connectors with a parameter setting.
0-10 V input	This option makes it possible to connect an external 0-10 V heat demand control. You can control the boiler based on temperature or power setpoint.

Options	Description
LIN-Bus	This option makes it possible to connect a LIN pump. The LIN-Bus protocol gives you more insight about the performance, diagnostics and failure detection of the pump.
Cascade management	This option makes it possible to link boilers in a cascade system. The S-Bus connections can be made externally on the Quick connect.



The combination of the extended connections and software features gives you more options as standard. The tables give an overview of the possible combinations.

- You can apply the desired fixed combination.
- You can extend the fixed combination with optional inputs and outputs.



Tab.30 Configurable inputs and outputs - Fixed combinations

Connector ⁽¹⁾	Status ▼ Nc C No	 1	 2
Boiler room ventilation: • Extractor fan (F ₁) • Extractor fan signal (F ₃)	F ₁		F ₃
(1) The letter F indicates a fixed combination of two connectors for each configuration.			

Tab.31 Configurable inputs and outputs - Extend options

Connector ⁽¹⁾⁽²⁾	Status ▼ Nc C No	 1	 2
Hydraulic valve	A ₁		
External gas valve	A ₁		
Status contact	A ₁		
Heat demand signal		A ₂	B ₃
Boiler relief signal		A ₂	B ₃
Blocking input		A ₂	B ₃
Release input		A ₂	B ₃
Gas pressure switch		A ₂	B ₃
(1) The letter A indicates the first option for the connection of each input or output. (2) The letter B indicates the second option for the connection of each input or output.			

Tab.32 Example of possible combinations

Connector	Status ▼ Nc C No	 1	 2
Fixed combination: Boiler room ventilation: • Extractor fan (F ₁) • Extractor fan signal (F ₃) Extended with: • Gas pressure switch (A ₂)	F ₁	A ₂	F ₃

To connect and configure the desired installation, please refer to:

- The following chapter for the available connectors.
- The connecting diagrams in the manual or online.

5.8.6 The CB-23 connection PCB

The **CB-23** is placed in the control box. It provides easy access to all the standard connectors.

Fig.55 Connection PCB CB-23

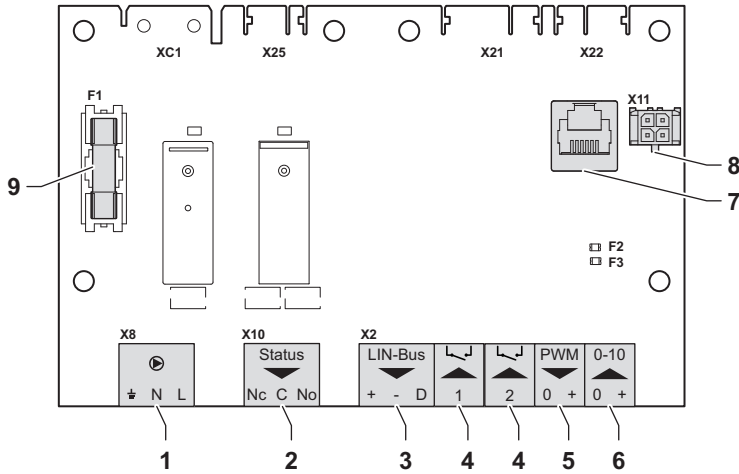

- 1 Pump connector, page 37
Connect a boiler pump.
- 2 Status connector, page 37
Connect a:
 - Extractor fan, page 38
 - Hydraulic valve, page 38
 - External gas valve, page 38
 - Status contact, page 38
- 3 LIN-Bus connector, page 38
Connect a LIN pump.
- 4 Programmable input connectors, page 38
Connect a:
 - Extractor fan signal, page 38
 - Heat demand signal, page 39
- 5 Pump PWM connector, page 40
Connect a PWM signal for the boiler pump.
- 6 0-10 V connector, page 40
Connect a 0-10 V signal.
- 7 Service port connector, page 40
Connect a service tool.
- 8 L-Bus connector, page 40
Connect the expansion box (L-Bus).
- 9 Fuse F1
Protects all connected components (for example, pumps, valves and PCBs).

AD-3002741-03

■ Pump connector

You can connect a boiler pump to the connector.

Connect the pump as follows:

- ⏏ Earth
- N Neutral
- L Phase

Fig.56 Pump connector



AD-3001306-02



Important

The maximum power consumption is 300 VA.

You can change the post run time, maximum speed and minimum speed with parameters **PP015**, **PP016** and **PP018**.



See also

Pump PWM connector, page 40

■ Status connector

You can connect a fan, range of pumps, two types of valves or a contact to the connector. You can configure it as required. Each configuration has a specific setting.

Connect the fan, pump, valve or contact as follows:

- Nc** Normally closed contact (contact will open when status occurs)
- C** Main contact
- No** Normally opened contact (contact will close when status occurs)

Fig.57 Status connector



AD-3002781-01



Important

The status connector functions as a potential free contact. Apply an external 230 V power supply for a fan, pump and valve.

Fig.58 Extractor fan



AD-3002781-01

- Extractor fan

You can connect an extractor fan for boiler room ventilation to the connector. When the appliance is active, the fan ventilates the room.



See also
Activating boiler room ventilation, page 58

Fig.59 Hydraulic valve



AD-3002781-01

- Hydraulic valve

You can connect a hydraulic valve to the connector. This valve isolates the appliance from the system.



See also
Setting the output, page 62

Fig.60 External gas valve



AD-3002781-01

- External gas valve

You can connect an external gas valve to the connector. This valve will follow the behaviour of the gas control valve in the appliance.



See also
Setting the output, page 62

Fig.61 Status contact



AD-3002781-01

- Status contact

You can connect a status contact to the connector. This contact will report the current status of the appliance to an external device or building management system.



See also
Setting the output, page 62

■ LIN-Bus connector

You can connect a LIN-Bus pump to the connector. The LIN-Bus controls the pump and receives data from the pump.



The LIN-Bus pumps from Grundfos have been tested and approved to work with the appliance. Pumps from other brands may also work, but have not been tested.

Fig.62 LIN-Bus connector



AD-3002779-01

Connect the LIN-Bus wires as follows:

- + Plus
- Minus
- D Signal

■ Programmable input connectors

You can connect a range of input signals to each connector. The programmable input connectors function as a potential free contact.



Two programmable connectors are available on the connection PCB. For more connections, you will need to use an expansion PCB.

You can configure it as required. Depending on the setting, a type of input signal can be connected.



The wires are interchangeable. It does not matter which wire is connected to which clamp.

Fig.63 Programmable input connectors

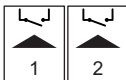

AD-3002780-01

Fig.64 Extractor fan signal



AD-3002780-01

- Extractor fan signal

You can connect an extractor fan feedback signal for boiler room ventilation to the connector. When the extractor fan is on, the contact will close.



See also
Activating boiler room ventilation, page 58

Fig.65 Heat demand signal

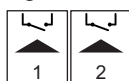

AD-3002780-01

- Heat demand signal

You can connect an on/off contact for central heating to the connector. This will generate a heat demand for central heating to the system.



See also
Setting the input, page 58

Fig.66 Boiler relief signal

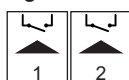

AD-3002780-01

- Boiler relief signal

You can connect a BMS to the connector. This will connect the appliance to a building management system that controls several heating appliances. Use this on/off contact to relieve the appliance for heat demands. The other appliances in the system can still take on heat production. For example:

- When the input is active, the appliance will not produce heat for central heating.
- When the input is active, the appliance will not produce heat for domestic hot water.
- When the input is active, the appliance will not produce heat for central heating and domestic hot water.

The input can be set to opened or closed for the relief of the heat demand.



See also
Setting the input, page 58

Fig.67 Blocking input

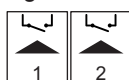

AD-3002780-01

- Blocking input

You can use the connector as a blocking input. This will block the appliance on request for specific types of heat demands. You can configure it as required. For example:

- The appliance will block heat demands for central heating.
- The appliance will block heat demands for domestic hot water.
- The appliance will block heat demands for central heating and domestic hot water.

The input can be set to opened or closed for the blocking of the heat demand. It is also possible to have the appliance show an error code.



See also
Setting the input, page 58

Fig.68 Release input

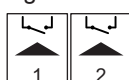

AD-3002780-01

- Release input

You can use the connector as a release input. This will release the appliance on request for specific types of heat demands. You can configure it as required. For example:

- The appliance will activate for domestic hot water and must be released for central heating demands.
- The appliance will not activate for central heating or domestic hot water and must be released for both heat demands.

The input can be set to opened or closed for the release of the heat demand.



See also
Setting the input, page 58

Fig.69 Gas pressure switch



AD-3002780-01

- Gas pressure switch

You can connect a gas pressure switch to the connector.

- When the gas pressure is too low, the switch will activate. This will block the appliance for 10 minutes and show the error code **H.01.09**.
- When the gas pressure is too high, the switch will activate. This will block the appliance for 10 minutes and show the error code **H.01.26**.

The input can be set to opened or closed for the switch activation.



See also
Setting the input, page 58

■ **Pump PWM connector**

You can connect a PWM pump signal wire to the connector. The PWM signal modulates and controls the boiler pump.

Connect the PWM signal wires as follows:

- 0 Zero
- + Plus

Fig.70 Pump PWM connector



AD-3002782-01

■ **0-10 V connector**

You can connect a 0-10 V heat demand to the connector. The 0-10 V signal has two modes:

- Control based on temperature setpoint.
- Control based on power setpoint.

Connect the 0-10 V signal as follows:

- Minus
- + Plus

Fig.71 0-10 V connector



AD-3001304-03

Fig.72 0-10 V control

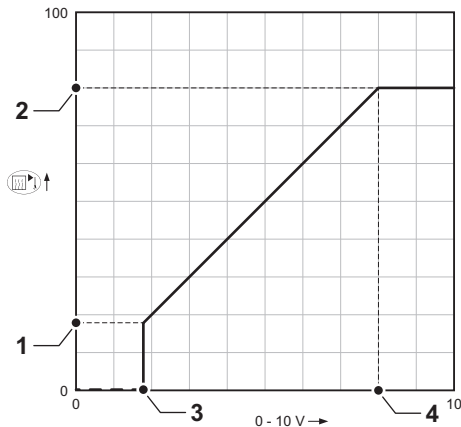

AD-3001543-01

You can change the mode of the analogue input with parameter **EP014**:

Temperature control: The 0-10 Volts controls the appliance flow temperature. The output varies between the minimum and maximum value on the basis of the flow temperature setpoint with a fixed power setpoint.

Power control: The 0-10 Volts controls the appliance heat output. The output will be converted towards a 0 – 100 % relative power setpoint with a fixed temperature setpoint. The minimum output is linked to the appliance modulation depth.

- 1 Minimum setpoint for temperature (parameter **EP030**) or power (parameter **EP032**)
- 2 Maximum setpoint for temperature (parameter **EP031**) or power (parameter **EP033**)
- 3 Minimum setpoint for voltage (parameter **EP034**)
- 4 Maximum setpoint for voltage (parameter **EP035**)

The measured values can be read with signals:

- EM010** The voltage on the 0-10 V input.
- EM018** When control based on temperature is set, the calculated temperature setpoint.
- EM021** When control based on heat output is set, the calculated power setpoint.

■ **Service port connector**

You can connect a service tool to the connector. The service tool connects to the following devices:

- Laptop
- Smart phone
- Tablet

You can use the Service tool Smart Service app to enter, change and read out various settings.

■ **L-Bus connector**

You can connect the cable for the expansion box to the connector. This extends the local bus to the expansion box.



The connector is already in use for the expansion box.

Fig.73 Service port connector (RJ12)



AD-3003112-01

Fig.74 L-Bus connector



AD-3003113-01

5.8.7 The SCB-10 expansion PCB

The SCB-10 has the following features:

- Control of 2 (mixing) zones
- Control of one domestic hot water (DHW) zone
- Cascade layout

You can combine the SCB-10 with the AD249. This will add the following features:

- Control of 1 extra (mixing) zone
- DHW circulation loop

Expansion PCBs are automatically recognised by the control unit of the boiler. If expansion PCBs are removed, the boiler will show an error code. To resolve this error, an auto-detect must be carried out after removal.

Fig.75 SCB-10 with AD249

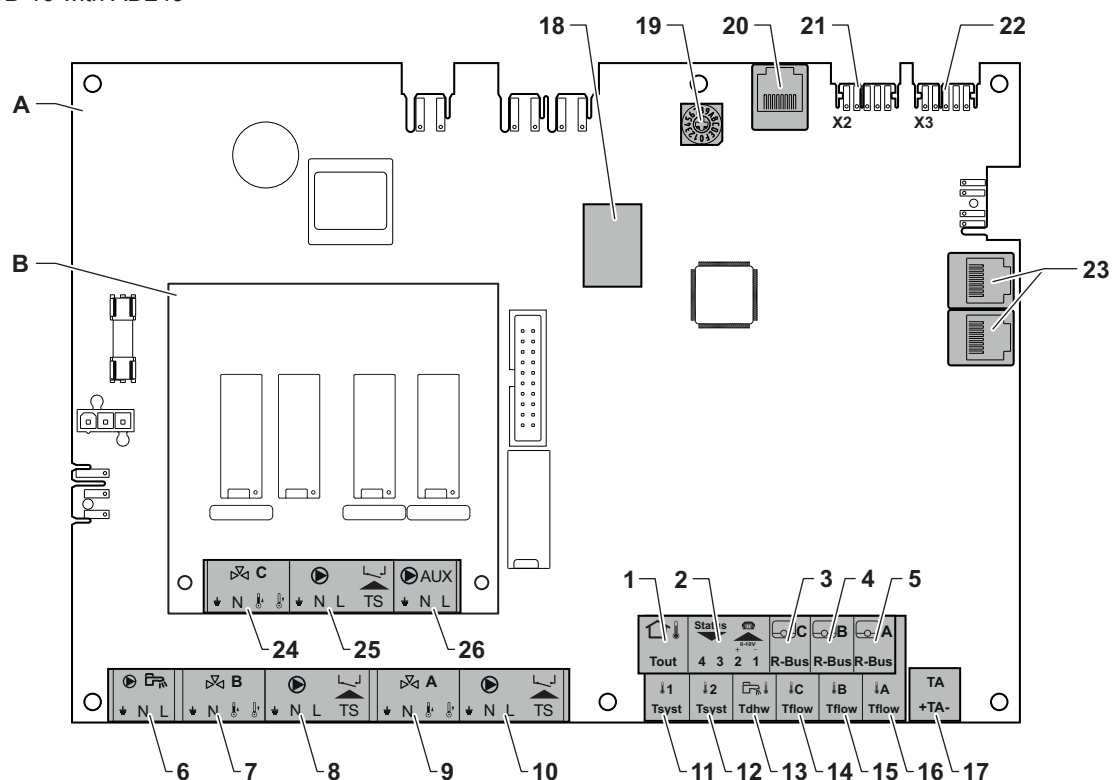

AD-3002665-01

- | | |
|---|---|
| A SCB-10 | 14 Flow temperature sensor - circuit C |
| B AD249 (optional) | 15 Flow temperature sensor - circuit B |
| 1 Outdoor temperature sensor | 16 Flow temperature sensor - circuit A |
| 2 Programmable and 0-10 V input | 17 Impressed current anode |
| 3 Room temperature sensor - circuit C | 18 Modbus connectors |
| 4 Room temperature sensor - circuit B | 19 Coding wheel, selects the producer number in the cascade in Mod-Bus |
| 5 Room temperature sensor - circuit A | 20 S-BUS connector |
| 6 DHW cylinder pump | 21 End connector for L-BUS connection |
| 7 Mixing valve - circuit B | 22 L-BUS connector |
| 8 Pump and thermal switch - circuit B | 23 S-BUS connector |
| 9 Mixing valve - circuit A | 24 Mixing valve - circuit C (optional) |
| 10 Pump and thermal switch - circuit A | 25 Pump and thermal switch - circuit C (optional) |
| 11 System sensor 1 | 26 DHW circulation loop pump (optional) |
| 12 System sensor 2 | |
| 13 DHW temperature sensor | |

■ Connecting a domestic hot water (DHW) pump

Connecting a domestic hot water (DHW) pump. The maximum power consumption is 300 VA.

Fig.76 DHW pump connector



AD-4000123-02

Connect the pump as follows:

- Earth
- N** Neutral
- L** Phase

■ **Connecting a mixing valve**

Connecting a mixing valve (230 VAC) per zone (group).

Connect the mixing valve as follows:

- Earth
- N** Neutral
- Open
- Close

Fig.77 Mixing valve connectors

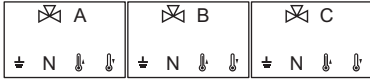

AD-3002668-01

■ **Connecting the pump with a protection thermostat**

Connecting a pump with a protection thermostat, for example underfloor heating. The maximum pump power consumption is 300 VA.

Connect the pump and the protection thermostat as follows:

- Earth
- N** Neutral
- L** Phase
- TS** protection thermostat (remove bridge)

Fig.78 Pump with protection thermostat connector



AD-3002669-01

■ **Connecting a DHW circulation pump**

Connecting a DHW circulation pump. The maximum power consumption is 300 VA.

Connect the pump as follows:

- Earth
- N** Neutral
- L** Phase

Fig.79 DHW circulation pump connector



AD-3002666-01

■ **Connecting an outdoor sensor**

An outdoor sensor can be connected to the **Tout** terminal of the connector. In the case of an on/off thermostat, the boiler will control the temperature with the set point from the internal heating curve.

Fig.80 Outdoor sensor



AD-4000006-04

■ **Connecting the input/output connector**

The input/output connector can be used to connect a remote control, a 0–10 V analogue input or as a status output.

The 0–10 V signal controls the boiler flow temperature in a linear way. This control modulates on the basis of flow temperature. The output varies between the minimum and maximum value on the basis of the flow temperature setpoint calculated by the controller.

Connect the input/output connector as follows:

- 1 + 2** 0–10 V / status input
- 3 + 4** status output

Fig.81 Input/output connector

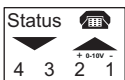

AD-4000004-03

■ **Connecting room thermostats per zone**

The SCB-10 is fitted with three **R-Bus** connectors. They can be used to connect room thermostats per zone. The **R-bus** connectors are related to the other zone-specific connectors on the SCB-10. The **R-Bus** connector supports the following types:

- **R-Bus** thermostat (for example, the **Smart TC°**)

Fig.82 R-Bus connectors

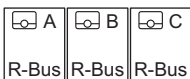

AD-4000003-03

Fig.83 System sensor connectors

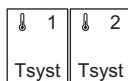

AD-4000008-03

Fig.84 DHW sensor



AD-4000009-03

Fig.85 Contact temperature sensor connectors

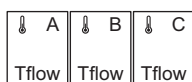

AD-4000007-03

Fig.86 Anode connector



AD-4000005-03

- **OpenTherm** thermostat
- **OpenTherm Smart Power** thermostat
- **On/off** thermostat

The software recognizes which type of thermostat is connected.

■ Connecting system sensors

Connecting system sensors (NTC 10k Ohm/25°C) for circuits (zones).

■ Connecting the domestic hot water (DHW) sensor

Connecting the domestic hot water (DHW) sensor (NTC 10k Ohm/25°C).

■ Connecting contact temperature sensors

Connecting contact temperature sensors (NTC 10k Ohm/25°C) for system flow, DHW temperatures or zones (groups).

■ Connecting the DHW cylinder anode

You can connect a TAS anode (Titan Active System) for a DHW cylinder to the connector.

Connect the anode as follows:

- + Plus, connection on the DHW cylinder
- Minus, connection on the anode



Important

If the DHW cylinder does not have a TAS anode, connect the simulation anode (optional).

6 Before commissioning

6.1 Checklist before commissioning

6.1.1 Filling the trap



Danger
Flue gas leakage
 Chance of CO poisoning.

- Make sure the trap is sufficiently filled with water.

Fig.87 Filling the trap

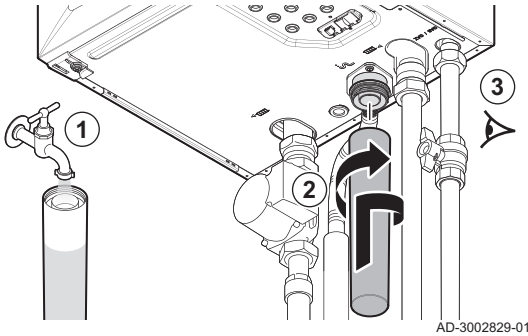

1. Fill the trap with water.
2. Fit the trap.
3. Check for leaks.

6.1.2 Filling the installation

The recommended water pressure is between 1.5 bar and 2.0 bar.

Proceed as follows to fill the installation:

1. Fill the central heating system with clean water.



Switch on the boiler to show the water pressure on the display.

2. Check the water-side connections for tightness.

6.1.3 Preparing the gas circuit



Danger of electric shock
High voltages
 Risk of electric shock.

- Always disconnect the mains power supply before working on the appliance.

Fig.88 Gas inlet pressure measuring point

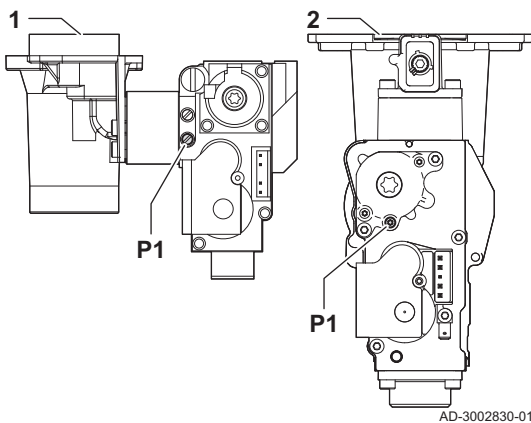

- 1 Gas control valve on the AMC PRO EVO 35 - 45 - 65 - 90
- 2 Gas control valve on the AMC PRO EVO 115

1. Open the main gas valve.
2. Open the boiler gas cock.
3. Check the tightness of the gas circuit.
4. Vent the gas supply pipe by unscrewing measuring point **P1**.
 ⇒ The gas supply pipe is properly vented when a gas smell can be noticed.
5. Check the gas inlet pressure at measuring point **P1**.
 The advised inlet pressure is shown on the data plate.



Danger
Gas leakage
 Chance of explosion.

- The inlet pressure may never exceed the maximum pressure mentioned in the technical data table.

6. Tighten the measuring point again.

6.2 Control panel description

6.2.1 Control panel components

Fig.89 Control panel components

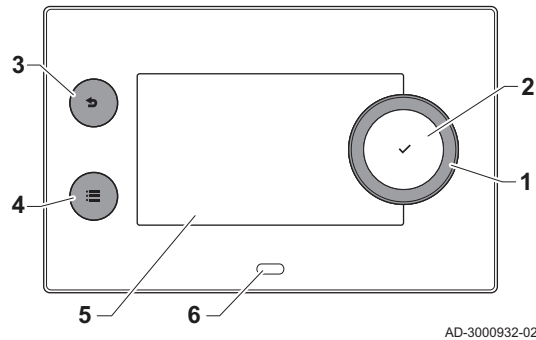

- 1 Rotary knob to select a tile, menu or setting
- 2 Confirm button ✓ to confirm the selection
- 3 Back button ←:
 - **Short button press:** Return to the previous level or previous menu
 - **Long button press:** Return to home screen
- 4 Menu button ≡ to go to the main menu
- 5 Display
- 6 Status LED

6.2.2 Description of the home screen

This screen is shown automatically after start-up of the appliance. The control panel automatically enters standby mode (black screen) if the buttons are not used for 5 minutes. Press one of the buttons on the control panel to activate the screen again.

You can navigate from any menu to the home screen by pressing the back button ← for several seconds.

The tiles on the home screen provide quick access to the corresponding menus. Use the rotary knob to navigate to the desired item and press the button ✓ to confirm the selection.

Fig.90 Icons on home screen

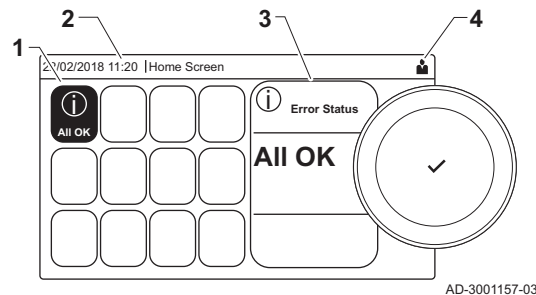

- 1 Tiles: the selected tile is highlighted.
- 2 Date and time | Name of the screen (actual position in the menu).
- 3 Information about the selected tile.
- 4 Icons indicating navigation level, operating mode, errors and other information.

6.2.3 Description of the main menu

You can navigate from any menu directly to the main menu by pressing the menu button ≡. The number of accessible menus depends on the access level (user or installer).

Fig.91 Items in the main menu

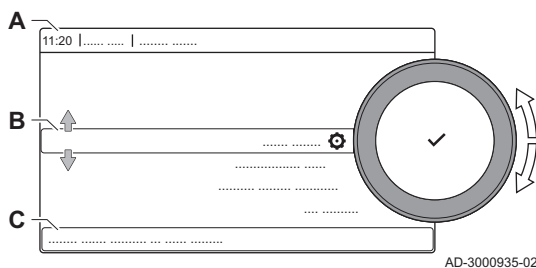





- A Date and time | Name of the screen (actual position in the menu)
- B Available menus
- C Brief explanation of the selected menu

Tab.33 Available menus for the user 👤

Description	Icon
Enable installer access	👤
System Settings	⚙️
Version Information	ℹ️



















Tab.34 Available menus for the installer 🛠️

Description	Icon
Disable installer access	👤
Installation Setup	🛠️













Description	Icon
Commissioning Menu	
Advanced Service Menu	
Error History	
System Settings	
Version Information	

6.2.4 Description of the icons in the display







Tab.35 Icons

Icon	Description
	User menu: user-level parameters can be configured.
	Installer menu: installer-level parameters can be configured.
	Information menu: read out various current values.
	System settings: system parameters can be configured.
	Error indicator.
	Gas boiler indicator.
	Domestic hot water tank is connected.
	The outdoor temperature sensor is connected.
	Boiler number in cascade system.
	The solar calorifier is on and its heat level is displayed.
	Burner output level (1 to 5 bars, with each bar representing 20% output).
	The pump is running.
	Three-way valve indicator.
	Display of the system water pressure.
	Chimney sweep mode is enabled (forced full load or low load for O ₂ measurement).
	Energy saving mode is enabled.
	DHW boost is enabled.
	Time program is enabled: The room temperature is controlled by a time program.
	Manual mode is enabled: The room temperature is set to a fixed setting.
	Temporary overwrite of the time program is enabled: The room temperature is changed temporarily.
	The holiday program (including frost protection) is active: The room temperature is reduced during your holiday to save energy.
	Frost protection is enabled: Protect the boiler and installation from freezing during winter.
	Service notification: service needed. Installer contact details are displayed or can be filled in.

Tab.36 Icons - On/off

Icon	Description	Icon	Description
	CH operation is enabled.		CH operation is disabled.
	DHW operation is enabled.		DHW operation is disabled.
	The burner is on.		The burner is off.
	Bluetooth enabled and connected (icon is non-transparent).		Bluetooth enabled and disconnected (icon is transparent).
	Heating enabled.		
	Cooling enabled.		
	Heating/cooling enabled.		Heating/cooling disabled.

Tab.37 Icons - Zones

Icon	Description
	All zones (groups) icon.
	Living room icon.
	Kitchen icon.
	Bedroom icon.
	Study icon.
	Cellar icon.

7 Commissioning

7.1 Commissioning procedure



Warning
Hazardous appliance
 Chance of injury.

- Installation, commissioning, maintenance, and decommissioning of the appliance and system must only be carried out by a qualified installer in accordance with regulations and the information given in the manual.



Notice
Gas-air fault
 Damage to the product.

- If adapting to another gas type, adjust the gas control valve before switching on the boiler.

1. Open the main gas valve.
2. Open the appliance gas valve.
3. Switch on the power with the boiler's on/off switch.
4. Configure the settings shown on the display.
 ⇒ The start-up program will start and cannot be interrupted.
5. Set the components (thermostats, controller) so that heat is demanded.



Important
 In the event of an error during the start-up, a message with the corresponding code is displayed. The meaning of the error codes can be found in the error table.

7.2 Gas settings

7.2.1 Factory setting

The factory setting of the boiler is for operation with the natural gas group G20 (H gas).

Tab.38 Factory settings G20 (H-gas)

Code	Display text	Description	Adjustment range	35	45	65	90	115
DP003	Abs max fan DHW	Maximum fan speed on Domestic Hot Water	1400 - 7500 Rpm	4700	5400	5600	6300	6800
GP007	Fan RPM Max CH	Maximum fan speed during Central Heating mode	1400 - 7500 Rpm	4700	5400	5600	6300	6800

Code	Display text	Description	Adjustment range	35	45	65	90	115
GP008	Fan RPM Min	Minimum fan speed during Central Heating + Domestic Hot Water mode	1000 - 4000 Rpm	1550	1550	1600	1600	1800
GP009	Fan RPM Start	Fan speed at appliance start	900 - 5000 Rpm	2500	2500	2500	2500	2500

7.2.2 Adjusting to a different gas type

Warning
Hazardous appliance
 Chance of injury.

- Installation, commissioning, maintenance, and decommissioning of the appliance and system must only be carried out by a qualified installer in accordance with regulations and the information given in the manual.

Important
 If the boiler is adapted to another gas type, this must be stated on the sticker supplied. This sticker must be affixed next to the data plate.

Before operating with a different type of gas, carry out the following steps.

■ **Adjusting the gas control valve for propane**

- 1 Gas control valve on the AMC PRO EVO 35 - 45 - 65 - 90
- 2 Gas control valve on the AMC PRO EVO 115

Important
 For the AMC PRO EVO 90 boiler: Replace the current gas control valve with the propane gas control valve according to the instructions supplied with the propane conversion kit.

1. Using adjusting screw **A**, adjust the factory setting to the setting for propane. The rotations for each boiler type are described in the table.

Fig.92 Position of adjusting screw A

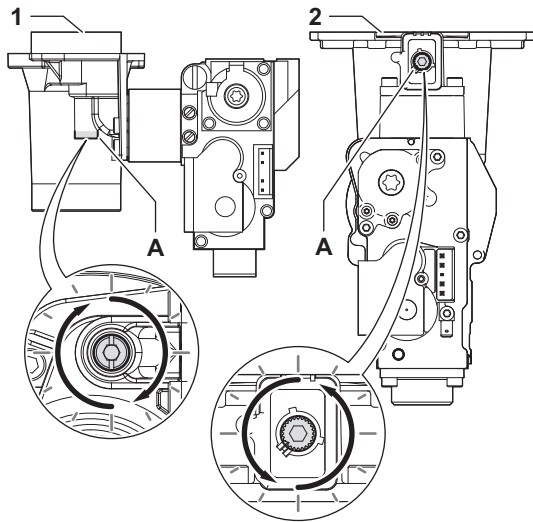

AD-3003280-01

Tab.39 Settings for propane

Boiler type	Action
AMC PRO EVO 35	Rotate the adjusting screw A on the venturi 4¾ turns in a clockwise direction.
AMC PRO EVO 45	Rotate the adjusting screw A on the venturi 4¾ turns in a clockwise direction.
AMC PRO EVO 65	Rotate the adjusting screw A on the venturi 6½ turns in a clockwise direction.
AMC PRO EVO 115	Rotate the adjusting screw A in a clockwise direction until it is fully opened. Rotate the adjusting screw A on the gas control valve 54 turns in an anticlockwise direction.

■ **Adjusting fan speed parameters for different gas types**

The factory fan speed settings can be adjusted for a different type of gas at installer level.

▶▶ **⚠ > Parameters, counters, signals > Parameters**

- 💡 Use the rotary knob to navigate.
- ✔ Use the button to confirm your selection.

1. Enable Installer access.
 - 1.1. Select the tile [🔑].
 - 1.2. Enter code: **0012**.
2. Select the tile [🔧].
3. Select **Parameters, counters, signals**.
4. Select **Parameters**.
5. Select the required parameter.
6. Change the setting.

■ Fan speed for different gas types

1. Adjust the fan speed parameters for the gas type used according to the table.
If a boiler is not suitable for a certain gas type, it is indicated with "-" in the table.

Tab.40 Adjustment for gas type G20 (H gas) (Switzerland)

Code	Display text	Description	Adjustment range	35	45	65	90	115
DP003	Abs max fan DHW	Maximum fan speed on Domestic Hot Water	1400 - 7500 Rpm	4700	5400	5600	6300	6800
GP007	Fan RPM Max CH	Maximum fan speed during Central Heating mode	1400 - 7500 Rpm	4700	5400	5600	6300	6800
GP008	Fan RPM Min	Minimum fan speed during Central Heating + Domestic Hot Water mode	1000 - 4000 Rpm	1550	1550	1600	1600	1850
GP009	Fan RPM Start	Fan speed at appliance start	900 - 5000 Rpm	2500	2500	2500	2500	2500

Tab.41 Adjustment for gas type G25 (L gas)

Code	Display text	Description	Adjustment range	35	45	65	90	115
DP003	Abs max fan DHW	Maximum fan speed on Domestic Hot Water	1400 - 7500 Rpm	4800	5600	5800	6300	7000
GP007	Fan RPM Max CH	Maximum fan speed during Central Heating mode	1400 - 7500 Rpm	4800	5600	5800	6300	7000
GP008	Fan RPM Min	Minimum fan speed during Central Heating + Domestic Hot Water mode	1000 - 4000 Rpm	1550	1550	1600	1650	1800
GP009	Fan RPM Start	Fan speed at appliance start	900 - 5000 Rpm	2500	2500	2500	2500	2500

Tab.42 Adjustment for gas type G30/G31 (butane/propane)

Code	Display text	Description	Adjustment range	35	45	65	90	115
DP003	Abs max fan DHW	Maximum fan speed on Domestic Hot Water	1400 - 7500 Rpm	4200	5100	5300	5800	6500
GP007	Fan RPM Max CH	Maximum fan speed during Central Heating mode	1400 - 7500 Rpm	4200	5100	5300	5800	6500
GP008	Fan RPM Min	Minimum fan speed during Central Heating + Domestic Hot Water mode	1000 - 4000 Rpm	1550	1550	1600	2250	1800
GP009	Fan RPM Start	Fan speed at appliance start	900 - 5000 Rpm	2500	2500	2500	2500	3500

Tab.43 Adjustment for gas type G30/G31 (butane/propane) (Switzerland)

Code	Display text	Description	Adjustment range	35	45	65	90	115
DP003	Abs max fan DHW	Maximum fan speed on Domestic Hot Water	1400 - 7500 Rpm	4200	5100	5300	5800	6500
GP007	Fan RPM Max CH	Maximum fan speed during Central Heating mode	1400 - 7500 Rpm	4200	5100	5300	5800	6500

Code	Display text	Description	Adjustment range	35	45	65	90	115
GP008	Fan RPM Min	Minimum fan speed during Central Heating + Domestic Hot Water mode	1000 - 4000 Rpm	1550	1550	1600	2250	1900
GP009	Fan RPM Start	Fan speed at appliance start	900 - 5000 Rpm	2500	2500	2500	2500	3500

Tab.44 Adjustment for gas type G31 (propane)

Code	Display text	Description	Adjustment range	35	45	65	90	115
DP003	Abs max fan DHW	Maximum fan speed on Domestic Hot Water	1400 - 7500 Rpm	4200	5100	5400	6000	6700
GP007	Fan RPM Max CH	Maximum fan speed during Central Heating mode	1400 - 7500 Rpm	4200	5100	5400	6000	6700
GP008	Fan RPM Min	Minimum fan speed during Central Heating + Domestic Hot Water mode	1000 - 4000 Rpm	1550	1550	1600	2000	1800
GP009	Fan RPM Start	Fan speed at appliance start	900 - 5000 Rpm	3000	3000	2500	2500	3500

2. Check the setting of the gas/air ratio.

7.2.3 Checking and setting the gas/air ratio

The flue gas analyser must have a minimum accuracy of $\pm 0.25\% O_2$, and ± 20 PPM CO.

Fig.93 Insert the probe for the flue gas analyser

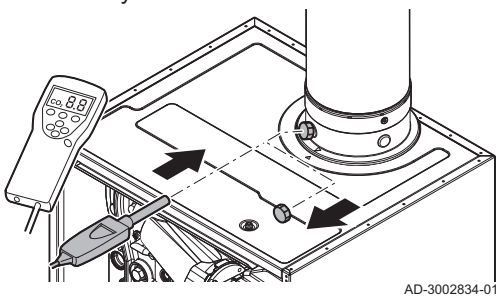

1. Remove the cap from the flue gas measuring point.
2. Insert the probe for the flue gas analyser into the measurement opening.



Danger

Flue gas leakage

Chance of CO poisoning.

- Fully seal the opening around the sensor during measurement.

3. Measure the percentage of O_2 and CO values in the flue gases. Take measurements at full load and at low load.



Important

- This appliance is suitable for category I_{2E} and I_{2Esi} and I_{2H} containing up to 20% Hydrogen gas (H₂). Due to variations in the H₂ percentage, the O₂ percentage can vary over time. (For example: a percentage of 20% H₂ in the gas can lead to an increase of 1,5% of O₂ in the flue gasses)
- A significant adjustment of the gas valve may be needed. Adjustment can be done using the standard O₂ values of the gas used.

■ **Performing the full load test**

1. Select the tile [👤].
⇒ The **Change load test mode** menu appears.
2. Select the test **Medium power**.

A Change load test mode

B Medium power

- ⇒ The full load test starts. The selected load test mode is shown in the menu and the icon 👤 appears in the top right of the screen.
3. Check the load test settings and adjust if necessary.
⇒ Only the parameters shown in bold can be changed.

Fig.94 Full load test

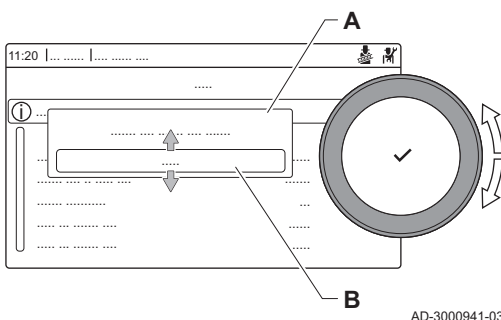

■ Checking/setting values for O₂ at full load

1. Set the boiler to full load.
2. Measure the percentage of O₂ in the flue gases.
3. Compare the measured value with the checking values in the table.
If a boiler is not suitable for a certain gas type, it is indicated with "-" in the table.

Tab.45 Checking/setting values for O₂ at full load for G20 (H gas)

Values at full load for G20 (H gas)	O ₂ (%) ⁽¹⁾
AMC PRO EVO 35	4,3 - 4,8 ⁽¹⁾
AMC PRO EVO 45	4,3 - 4,8 ⁽¹⁾
AMC PRO EVO 65	4,3 - 4,8 ⁽¹⁾
AMC PRO EVO 90	4,3 - 4,7 ⁽¹⁾
AMC PRO EVO 115	3,9 - 4,4 ⁽¹⁾
(1) Nominal value.	

Tab.46 Checking/setting values for O₂ at full load for G20 (H gas) (Switzerland)

Values at full load for G20 (H gas)	O ₂ (%) ⁽¹⁾
AMC PRO EVO 35	4,3 - 4,8 ⁽¹⁾
AMC PRO EVO 45	4,3 - 4,8 ⁽¹⁾
AMC PRO EVO 65	4,3 - 4,8 ⁽¹⁾
AMC PRO EVO 90	4,3 - 4,7 ⁽¹⁾
AMC PRO EVO 115	4,3 - 4,7 ⁽¹⁾
(1) Nominal value.	

Tab.47 Checking/setting values for O₂ at full load for G25 (L gas)

Values at full load for G25 (L gas)	O ₂ (%) ⁽¹⁾
AMC PRO EVO 35	4,1 - 4,6 ⁽¹⁾
AMC PRO EVO 45	4,1 - 4,6 ⁽¹⁾
AMC PRO EVO 65	4,1 - 4,6 ⁽¹⁾
AMC PRO EVO 90	3,7 - 4,1 ⁽¹⁾
AMC PRO EVO 115	4,0 - 4,4 ⁽¹⁾
(1) Nominal value.	

Tab.48 Checking/setting values for O₂ at full load for G31 (propane)

Values at full load for G31 (propane)	O ₂ (%) ⁽¹⁾
AMC PRO EVO 35	4,4 - 4,9 ⁽¹⁾
AMC PRO EVO 45	4,4 - 4,9 ⁽¹⁾
AMC PRO EVO 65	4,6 - 4,9 ⁽¹⁾
AMC PRO EVO 90	4,9 - 5,2 ⁽¹⁾
AMC PRO EVO 115	4,4 - 4,9 ⁽¹⁾
(1) Nominal value.	

Tab.49 Checking/setting values for O₂ at full load for G30/G31 (butane/propane)

Values at full load for G30/G31 (butane/propane)	O ₂ (%) ⁽¹⁾
AMC PRO EVO 35	4,7 - 5,2 ⁽¹⁾
AMC PRO EVO 45	4,7 - 5,2 ⁽¹⁾
AMC PRO EVO 65	4,9 - 5,4 ⁽¹⁾

Values at full load for G30/G31 (butane/propane)	O ₂ (%) ⁽¹⁾
AMC PRO EVO 90	4,9 - 5,4 ⁽¹⁾
AMC PRO EVO 115	4,4 - 4,9 ⁽¹⁾
(1) Nominal value.	

Tab.50 Checking/setting values for O₂ at full load for G30/G31 (butane/propane) (Switzerland)

Values at full load for G30/G31 (butane/propane)	O ₂ (%) ⁽¹⁾
AMC PRO EVO 35	4,7 - 5,2 ⁽¹⁾
AMC PRO EVO 45	4,7 - 5,2 ⁽¹⁾
AMC PRO EVO 65	4,9 - 5,4 ⁽¹⁾
AMC PRO EVO 90	4,9 - 5,4 ⁽¹⁾
AMC PRO EVO 115	4,7 - 5,2 ⁽¹⁾
(1) Nominal value.	

Notice
Incorrect settings
 Damage to the product.
 - The O₂ values at full load must be lower than the O₂ values at low load.

- If the measured value is outside of the values given in the table, correct the gas/air ratio.

Warning
Hazardous appliance
 Chance of injury.
 - Installation, commissioning, maintenance, and decommissioning of the appliance and system must only be carried out by a qualified installer in accordance with regulations and the information given in the manual.

- Use the adjusting screw **A** to set the percentage of O₂ for the gas type being used to the nominal value. This must always be inside the highest and lowest setting limit. Increasing the gas flow, will decrease O₂. See drawing for the position of adjusting screw **A** for full load.

- Gas control valve on the AMC PRO EVO 35 - 45 - 65 - 90
- Gas control valve on the AMC PRO EVO 115

- Check the flame through the inspection glass. The flame must not blow off.
- Measure the CO value in the flue gasses. If the CO level is above 400 ppm perform the following actions:

i Important
 The CO-concentration in the flue gasses must always comply with the installation regulations of the country in which the boiler is installed.

- Check if the flue gas discharge system is installed correctly.
- Check if the used gas type matches with the boiler settings.
- Check the burner for damage and clean the burner.
- Recheck the gas/air ratio setting.
- Contact your supplier if the CO level is still above 400 ppm.

Notice
Incorrect settings
 Damage to the product.
 • If the CO level is above 1000 ppm, switch off the boiler and contact your supplier.

■ **Performing the low load test**

- If the full load test is still running, press the ✓ button to change the load test mode.

Fig.95 Position of adjusting screw A

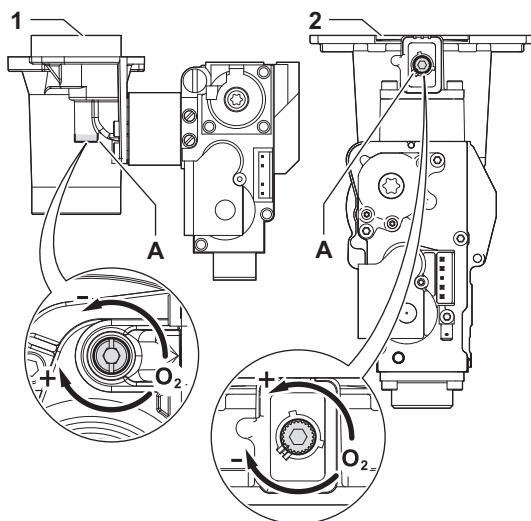

AD-3002831-01

Fig.96 Low load test

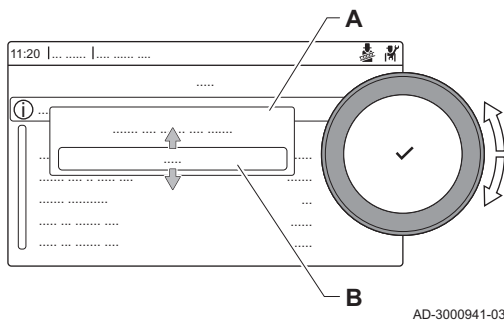

- If the full load test was finished, select the tile [🧹] to restart the chimney sweep menu.

A Change load test mode
B Low power

- Select the **Low power** test in the menu **Change load test mode**.
 ⇒ The low load test starts. The selected load test mode is shown in the menu and the icon 🧹 appears in the top right of the screen.
- Check the load test settings and adjust if necessary.
 ⇒ Only the parameters shown in bold can be changed.
- End the low load test by pressing the ⏪ button.
 ⇒ The message **Running load test(s) stopped!** is displayed.

■ **Checking/setting values for O₂ at low load**

- Set the boiler to low load.
- Measure the percentage of O₂ in the flue gases.
- Compare the measured value with the checking values in the table.
 If a boiler is not suitable for a certain gas type, it is indicated with "-" in the table.

Tab.51 Checking/setting values for O₂ at low load for G20 (H gas)

Values at low load for G20 (H gas)	O ₂ (%) ⁽¹⁾
AMC PRO EVO 35	5,7 ⁽¹⁾ - 6,2
AMC PRO EVO 45	5,7 ⁽¹⁾ - 6,2
AMC PRO EVO 65	4,8 ⁽¹⁾ - 5,3
AMC PRO EVO 90	5,2 ⁽¹⁾ - 5,5
AMC PRO EVO 115	5,7 ⁽¹⁾ - 6,2
(1) Nominal value.	

Tab.52 Checking/setting values for O₂ at low load for G20 (H gas) (Switzerland)

Values at low load for G20 (H gas)	O ₂ (%) ⁽¹⁾
AMC PRO EVO 35	5,7 ⁽¹⁾ - 6,2
AMC PRO EVO 45	5,7 ⁽¹⁾ - 6,2
AMC PRO EVO 65	4,8 ⁽¹⁾ - 5,3
AMC PRO EVO 90	5,2 ⁽¹⁾ - 5,6
AMC PRO EVO 115	5,9 ⁽¹⁾ - 6,4
(1) Nominal value.	

Tab.53 Checking/setting values for O₂ at low load for G25 (L gas)

Values at low load for G25 (L gas)	O ₂ (%) ⁽¹⁾
AMC PRO EVO 35	5,5 ⁽¹⁾ - 6,0
AMC PRO EVO 45	5,5 ⁽¹⁾ - 6,0
AMC PRO EVO 65	4,6 ⁽¹⁾ - 5,1
AMC PRO EVO 90	5,3 ⁽¹⁾ - 5,6
AMC PRO EVO 115	5,7 ⁽¹⁾ - 6,2
(1) Nominal value.	

Tab.54 Checking/setting values for O₂ at low load for G31 (propane)

Values at low load for G31 (propane)	O ₂ (%) ⁽¹⁾
AMC PRO EVO 35	5,4 ⁽¹⁾ - 5,9
AMC PRO EVO 45	5,7 ⁽¹⁾ - 6,2
AMC PRO EVO 65	5,4 ⁽¹⁾ - 5,7

Values at low load for G31 (propane)	O ₂ (%) ⁽¹⁾
AMC PRO EVO 90	5,5 ⁽¹⁾ - 5,8
AMC PRO EVO 115	6,1 ⁽¹⁾ - 6,6
(1) Nominal value.	

Tab.55 Checking/setting values for O₂ at low load for G30/G31 (butane/propane)

Values at low load for G30/G31 (butane/propane)	O ₂ (%) ⁽¹⁾
AMC PRO EVO 35	5,7 ⁽¹⁾ - 6,2
AMC PRO EVO 45	5,7 ⁽¹⁾ - 6,2
AMC PRO EVO 65	5,7 ⁽¹⁾ - 6,2
AMC PRO EVO 90	5,7 ⁽¹⁾ - 6,2
AMC PRO EVO 115	6,1 ⁽¹⁾ - 6,6
(1) Nominal value.	

Tab.56 Checking/setting values for O₂ at low load for G30/G31 (butane/propane) (Switzerland)

Values at low load for G30/G31 (butane/propane)	O ₂ (%) ⁽¹⁾
AMC PRO EVO 35	5,7 ⁽¹⁾ - 6,2
AMC PRO EVO 45	5,7 ⁽¹⁾ - 6,2
AMC PRO EVO 65	5,7 ⁽¹⁾ - 6,2
AMC PRO EVO 90	5,7 ⁽¹⁾ - 6,2
AMC PRO EVO 115	6,7 ⁽¹⁾ - 7,1
(1) Nominal value.	



Notice
Incorrect settings

Damage to the product.

- The O₂ values at low load must be higher than the O₂ values at full load.

- If the measured value is outside of the values given in the table, correct the gas/air ratio.



Warning
Hazardous appliance

Chance of injury.

- Installation, commissioning, maintenance, and decommissioning of the appliance and system must only be carried out by a qualified installer in accordance with regulations and the information given in the manual.

Fig.97 Position of adjusting screw B

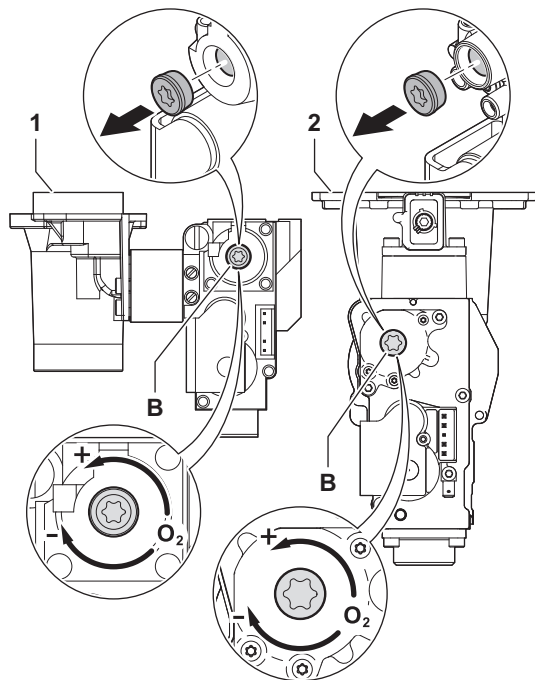

AD-3002832-01

- Use the adjusting screw **B** to set the percentage of O₂ for the gas type being used to the nominal value.
Increasing the gas flow, will decrease O₂.
See drawing for the position of adjusting screw **B** for low load.

- Gas control valve on the AMC PRO EVO 35 - 45 - 65 - 90
- Gas control valve on the AMC PRO EVO 115

- Check the flame through the inspection glass. The flame must not blow off.
- Repeat the full load test and the low load test as often as necessary until the correct values are obtained.
- Measure the CO value in the flue gasses. If the CO level is above 400 ppm perform the following actions:

i Important
The CO-concentration in the flue gasses must always comply with the installation regulations of the country in which the boiler is installed.

- Check if the flue gas discharge system is installed correctly.
- Check if the used gas type matches with the boiler settings.
- Check the burner for damage and clean the burner.
- Recheck the gas/air ratio setting.
- Contact your supplier if the CO level is still above 400 ppm.

! Notice
Incorrect settings
Damage to the product.
• If the CO level is above 1000 ppm, switch off the boiler and contact your supplier.

- Set the boiler back to the normal operating status.

7.3 Final instructions

- Remove the measuring equipment.
- Screw the cap on to the flue gas measuring point.
- Seal the gas control valve.
- Put the front panel back.
- Heat up the central heating system to approximately 70°C.
- Switch the boiler off.
- Vent the central heating system after approx. 10 minutes.
- Turn on the boiler.
- Check the water pressure. If necessary, top up the central heating system.
- Fill in the following data on the sticker included, and attach it next to the data plate on the appliance.
 - The gas type, if adapted to another gas;
 - The gas supply pressure;
 - The flue type, if set to overpressure application;
 - The parameters modified for the changes mentioned above;
 - Any fan speed parameters modified for other purposes.
- Optimise the settings as required for the system and user preferences.

Fig.98 Example filled-in sticker

Adjusted for / Réglée pour / Ingesteld op / Eingestellt auf / Regolato per / Ajustado para / Ρυθμισμένο για / Nastawiony na / настроен для / Reglat pentru / настроен за / ayarlanmıştır / Nastavljen za / beállítva/ Nastaveno pro / Asetettu kaasulle / Justert for/ indstillet til/ ل ضبط :	Parameters / Paramètres / Parameter / Parametri / Parámetros / Παράμετροι / Parametry / Параметры / Parametrii / Параметри / Parametreler / Paraméterek / Parametrit / Parametere / Parametre / شامل عمل :
<input checked="" type="checkbox"/> Gas G20 20 mbar	DP003 - 3300 GP007 - 3300 GP008 - 2150 GP009 -
<input checked="" type="checkbox"/> C _{(10)3(x)} <input type="checkbox"/> C _{(11)3(x)} <input type="checkbox"/> C _{(13)3(x)} <input type="checkbox"/> C _{(12)3(x)}	

AD-3001124-02

- See**
For more information; Settings, page 56 and User instructions, page 97.
- Save the commissioning settings on the control panel, so they can be restored after a reset.
 - Instruct the user in the operation of the system, boiler and controller.
 - Inform the user of the maintenance to be performed.
 - Hand over all manuals to the user.

7.3.1 Saving the commissioning settings

You can save all current settings on the control panel. These settings can be restored if necessary, for example after replacement of the control unit.

▶▶ ≡ > **Advanced Service Menu** > **Save as commissioning settings**

- 💡 Use the rotary knob to navigate.
- ✔ Use the ✔ button to confirm your selection.

1. Press the ≡ button.
2. Select **Advanced Service Menu**.
3. Select **Save as commissioning settings**.
4. Select **Confirm** to save the settings.

When you have saved the commissioning settings, the option **Revert commissioning settings** becomes available in the **Advanced Service Menu**.

8 Settings

8.1 Introduction to parameter codes

Fig.99 Code on a Diematic Evolution

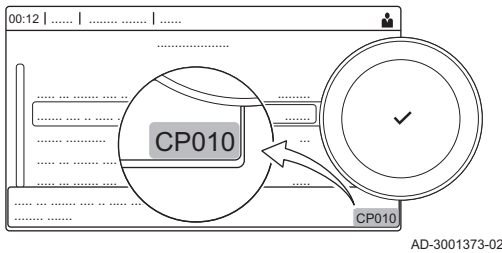

The controls platform makes use of an advanced system to categorise parameters, measurements and counters. Knowing the logic behind these codes, makes it easier to identify them. The code consists of two letters and three numbers.

Fig.100 First letter



The first letter is the category the code relates to.

- A** Appliance: Appliance
- B** Buffer: Hot water tank
- C** Circuit: Zone
- D** Domestic hot water: Domestic hot water
- E** External: External options
- G** Gas fired: Gas-fired heat engine
- N** Network: Cascade
- P** Producer: Central heating
- Z** Zone: Zone

Category D codes are appliance controlled only. When the domestic hot water is controlled by an SCB, it is handled like a circuit, with C-category codes.

Fig.101 Second letter



The second letter is the type.

- P** Parameter: Parameters
- C** Counter: Counters
- M** Measurement: Signals

Fig.102 Number



The number is always three digits. In certain cases, the last of the three digits relates to a zone.

8.2 Accessing the installer level

Some settings are protected by installer access. Enable installer access in order to change these settings.

- 💡 Use the rotary knob to navigate.
- ✔ Use the ✔ button to confirm your selection.

Fig.103 Installer level

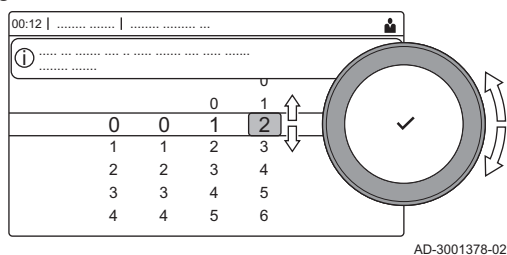

AD-3001378-02





1. Access the installer level via the tile:
 - 1.1. Select the tile [].
 - 1.2. Use code: **0012**.
 - ⇒ The tile [] shows that the installer access is **On**, and the icon in the top right of the display changes into .

Fig.104 Installer level

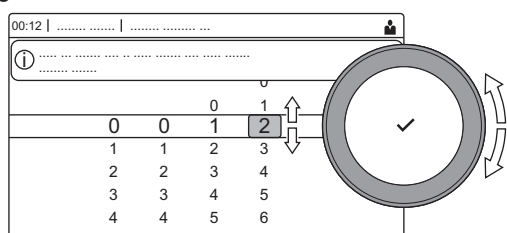

AD-3001378-02

2. Access the installer level via the menu:
 - 2.1. Select **Enable installer access** from the **Main Menu**.
 - 2.2. Use code: **0012**.
 - ⇒ When the installer level is enabled or disabled, the status of the tile [] changes into **On** or **Off**.

When the control panel is not used for 30 minutes, the installer access is disabled automatically. You can manually disable installer access via the tile [] or the **Main Menu** by selecting **Disable installer access**.

8.3 Searching the parameters, counters and signals

You can search and change data points (Parameters, counters, signals) of the appliance, connected control boards and sensors.

▶▶ ≡ > **Installation Setup > Search datapoints**



Use the rotary knob to navigate.
Use the  button to confirm your selection.

1. Press the ≡ button.
2. Select **Installation Setup**.
3. Select **Search datapoints**.
4. Select the search criteria (code):
 - 4.1. Select the first letter (datapoint category).
 - 4.2. Select the second letter (datapoint type).
 - 4.3. Select the first number.
 - 4.4. Select the second number.
 - 4.5. Select the third number.



The * symbol can be used to indicate any character within the search field.

Fig.105 Search

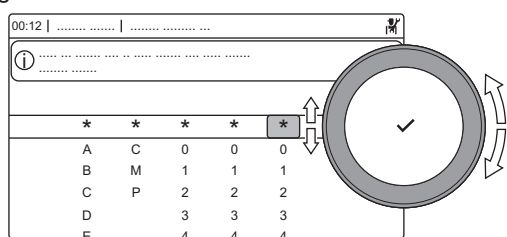

AD-3001916-01

Fig.106 List of datapoints

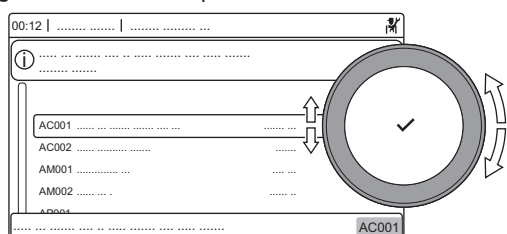

AD-3001917-01

- ⇒ The list of datapoints appears in the display. Only the first 30 results are shown when searching.
5. Select the desired datapoint.

8.4 Setting the fixed combinations

You can configure the functionality of the configurable input and output connectors with the following preconfigured settings.

i Important
Some of the configurable input and output connectors will be used by these configurations. You will no longer be able to manually configure these inputs/outputs when enabling these configurations.

Fig.107 Setting the fixed combinations

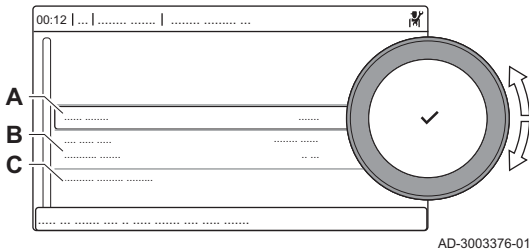

- A Enable or disable the function
- B List of relevant settings
- C Quick access to relevant parameters and signals

8.4.1 Activating boiler room ventilation

Activate boiler room ventilation by enabling the **Boiler room ventilation** function.

▶▶ ≡ > **Installation Setup** > **Boiler room ventilation** > **Enabled**

- 💡 Use the rotary knob to navigate.
- Use the ✓ button to confirm your selection.

i Important
This function uses Digital input 2 and Multifunctional out 2.

1. Press the ≡ button.
2. Select **Installation Setup**.
3. Select **Boiler room ventilation**.
4. Select **Toggle function**.
5. Select **Enabled**.

8.5 Setting the inputs and outputs

You can configure the functionality of the configurable input and output connectors manually.

i Important
Some of the configurable input and output connectors could be in use by the preconfigured fixed combinations. Disable the conflicting fixed configuration if you encounter an error while configuring the inputs or outputs.

Fig.108 Setting the inputs and outputs

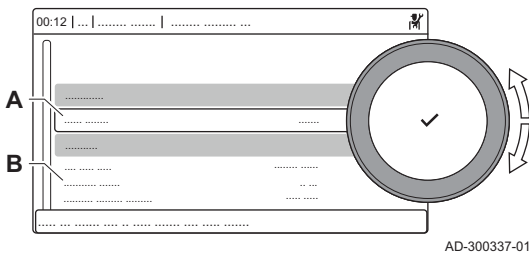

- A Configure the function
- B List of relevant settings

8.5.1 Setting the input

You can configure the input to support a wide range of different functionalities.

▶▶ ≡ > **Installation Setup** > **Digital input**



Use the rotary knob to navigate.

Use the ✓ button to confirm your selection.

1. Press the ≡ button.
2. Select **Installation Setup**.
3. Select **Digital input 1** or **Digital input 2**.
This menu lists all parameters for configuring the input.

■ Input settings

Tab.57 Input setting - None

Setting	Use and possible settings
None	No feature selected.

Tab.58 Input setting - Gas pressure switch

Setting	Use and possible settings
Min gas pressure Minimum gas pressure switch function.	On/off contact to connect a gas pressure switch for low gas pressure detection. When the gas pressure is too low, all heat demands are blocked. Logic level Logic level of the multifunctional inputs 0 = Normally open The boiler is blocked when the input is open 1 = Normally closed The boiler is blocked when the input is closed GPS Check Gas Pressure Switch check on/off 0 = No Gas pressure is not monitored 1 = Yes Gas pressure is monitored
Max gas pressure Maximum gas pressure switch function.	On/off contact to connect a gas pressure switch for high gas pressure detection. When the gas pressure is too high, all heat demands are blocked. Logic level Logic level of the multifunctional inputs 0 = Normally open The boiler is blocked when the input is open 1 = Normally closed The boiler is blocked when the input is closed GPS Check Gas Pressure Switch check on/off 0 = No Gas pressure is not monitored 1 = Yes Gas pressure is monitored

Tab.59 Input setting - Blocking input

Setting	Use and possible settings
Block CH Block CH.	<p>On/off contact to block the central heating function of the appliance.</p> <p>Logic level Logic level of the multifunctional inputs 0 = Normally open Heat demands for central heating are blocked when the input is open 1 = Normally closed Heat demands for central heating are blocked when the input is closed</p> <p>Display error Selects if this function will display an error when the function is active 0 = No Error code is not shown when heat demands for central heating are blocked 1 = Yes Error code is shown when heat demands for central heating are blocked</p> <p>Block frost protect Selects if this function will block frost protection 0 = No Frost protection for central heating is not blocked when Block CH is active 1 = Yes Frost protection for central heating is blocked when Block CH is active</p>
Block DHW Block DHW.	<p>On/off contact to block the domestic hot water function of the appliance.</p> <p>Logic level Logic level of the multifunctional inputs 0 = Normally open Heat demands for domestic hot water are blocked when the input is open 1 = Normally closed Heat demands for domestic hot water are blocked when the input is closed</p> <p>Display error Selects if this function will display an error when the function is active 0 = No Error code is not shown when heat demands for domestic hot water are blocked 1 = Yes Error code is shown when heat demands for domestic hot water are blocked</p> <p>Block frost protect Selects if this function will block frost protection 0 = No Frost protection for domestic hot water is not blocked when Block DHW is active 1 = Yes Frost protection for domestic hot water is blocked when Block DHW is active</p>
Block CH+DHW Block CH+DHW.	<p>On/off contact to block both the central heating and domestic hot water function of the appliance.</p> <p>Logic level Logic level of the multifunctional inputs 0 = Normally open Heat demands for central heating and domestic hot water are blocked when the input is open 1 = Normally closed Heat demands for central heating and domestic hot water are blocked when the input is closed</p> <p>Display error Selects if this function will display an error when the function is active 0 = No Error code is not shown when heat demands for central heating and domestic hot water are blocked 1 = Yes Error code is shown when heat demands for central heating and domestic hot water are blocked</p> <p>Block frost protect Selects if this function will block frost protection 0 = No Frost protection for central heating and domestic hot water is not blocked when Block CH+DHW is active 1 = Yes Frost protection for central heating and domestic hot water is blocked when Block CH+DHW is active</p>
Lock appliance Lock appliance.	<p>On/off contact to generate a lock-out error.</p> <p>Logic level Logic level of the multifunctional inputs 0 = Normally open The appliance is locked when the input is open 1 = Normally closed The appliance is locked when the input is closed</p> <p> To resolve the lock-out error, you must reset the appliance.</p>

Tab.60 Input setting - Release input

Setting	Use and possible settings
Release CH Release CH	<p>On/off contact to release the central heating function. The release of the contact will activate the appliance to produce heat for central heating.</p> <p>Logic level Logic level of the multifunctional inputs 0 = Normally open Heat demands for central heating are released when the input is open 1 = Normally closed Heat demands for central heating are released when the input is closed</p> <p>Timeout Amount of time before the function will timeout 0 - 65535 Sec Set the amount of time between the heat demand and the appliance timeout. When the appliance is not released within the time, the appliance will be blocked for 10 minutes</p> <p>Block frost protect Selects if this function will block frost protection 0 = No Frost protection for central heating is never blocked 1 = Yes Frost protection for central heating is blocked until the appliance is released</p>
Release CH+DHW Release CH+DHW	<p>On/off contact to release the central heating and domestic hot water function. The release of the contact will activate the appliance to produce heat for central heating and domestic hot water.</p> <p>Logic level Logic level of the multifunctional inputs 0 = Normally open Heat demands for central heating and domestic hot water are released when the input is open 1 = Normally closed Heat demands for central heating and domestic hot water are released when the input is closed</p> <p>Timeout Amount of time before the function will timeout 0 - 65535 Sec Set the amount of time between the heat demand and the appliance timeout. When the appliance is not released within the time, the appliance will be blocked for 10 minutes</p> <p>Block frost protect Selects if this function will block frost protection 0 = No Frost protection for central heating and domestic hot water is never blocked 1 = Yes Frost protection for central heating and domestic hot water is blocked until the appliance is released</p>

Tab.61 Input setting - Boiler relief signal

Setting	Use and possible settings
Relieve from CH Relieve from CH demand.	On/off contact to relieve the appliance for central heating. Use this when other appliances can also produce heat for central heating. When the appliance is relieved for a heat demand, the pump activates only the appliance will not produce heat. Logic level Logic level of the multifunctional inputs 0 = Normally open Heat demands for central heating are relieved by other appliances when the input is open 1 = Normally closed Heat demands for central heating are relieved by other appliances when the input is closed
Relieve from DHW Relieve from DHW demand.	On/off contact to relieve the appliance for domestic hot water. Use this when other appliances can also produce heat for domestic hot water. When the appliance is relieved for a heat demand, the pump activates only the appliance will not produce heat. Logic level Logic level of the multifunctional inputs 0 = Normally open Heat demands for domestic hot water are relieved by other appliances when the input is open 1 = Normally closed Heat demands for domestic hot water are relieved by other appliances when the input is closed
Relieve CH+DHW Relieve from CH +DHW demand.	On/off contact to relieve the appliance for central heating and domestic hot water. Use this when other appliances can also produce heat for central heating and domestic hot water. When the appliance is relieved for a heat demand, the pump activates only the appliance will not produce heat. Logic level Logic level of the multifunctional inputs 0 = Normally open Heat demands for central heating and domestic hot water are relieved by other appliances when the input is open 1 = Normally closed Heat demands for central heating and domestic hot water are relieved by other appliances when the input is closed

Tab.62 Input setting - Heat demand signal

Setting	Use and possible settings
Extern heat request External heat request.	On/off contact to generate a heat demand from the appliance. Logic level Logic level of the multifunctional inputs 0 = Normally open Heat demand for central heating is active when the input is open 1 = Normally closed Heat demand for central heating is active when the input is closed Temperature setpoint Temperature setpoint requested when the input is active 0 - 100 °C Set the temperature setpoint for the heat demand from the appliance

8.5.2 Setting the output

You can configure the output to support a wide range of different functionalities.

▶▶ ≡ > **Installation Setup > Multifunctional out**



Use the rotary knob to navigate.

Use the ✓ button to confirm your selection.

1. Press the ≡ button.
2. Select **Installation Setup**.
3. Select **Multifunctional out 1** or **Multifunctional out 2**.
This menu lists all parameters for configuring the output.

■ Output settings

Tab.63 Output settings - None

Setting	Use and possible settings
None	No feature selected.

Tab.64 Output setting - External gas valve

Setting	Use and possible settings
External gas valve External gas valve (EGV) function.	Contact to connect an external gas valve. The external gas valve opens and closes at the same time as the gas control valve in the appliance. No additional settings available.

Tab.65 Output setting - Hydraulic valve

Setting	Use and possible settings
Hydraulic valve Hydraulic valve (HDV) function.	Contact to connect a hydraulic valve. When the appliance is not producing heat, this valve isolates the appliance from the (cascade) system. This prevents water flow through the inactive appliance in a system with a single cascade pump. Hydr valve wait time Heat generator wait time to open the hydraulic valve 0 - 255 Sec Set the waiting time for the hydraulic valve to be opened. After the waiting time, the appliance will produce heat

Tab.66 Output setting - Status contact

Setting	Use and possible settings
Locking Notify external system when there is a locking error.	Status contact to report a lock-out error. No additional settings available.
Locking or blocking Notify external system when there is a locking or blocking error.	Status contact to report a lock-out or blocking error. No additional settings available.
Burning Notify external system if the burner is burning.	Status contact to report that the burner is active. No additional settings available.
Service request Notify external systems when there is a service request.	Status contact to report that there is a service request. No additional settings available.
Boiler on CH Notify external system when the boiler is producing for central heating.	Status contact to report that there is a request for central heating. No additional settings available.
Boiler on DHW Notify external system when the boiler is producing for domestic hot water.	Status contact to report that there is a request for domestic hot water. No additional settings available.
CH pump on Notify external system when the central heating pump is on.	Status contact to report that the central heating pump is on. No additional settings available.
DHW pump on Notify external system when the DHW pump is on.	Status contact to report that the domestic hot water pump is on. No additional settings available.

8.6 List of parameters

8.6.1 CU-GH22 control unit parameters

All tables show the factory setting for the parameters.

**Important**

The tables also list parameters that are only applicable if the boiler is combined with other equipment.

Tab.67 Navigation for basic installer level

Level	Menu path
Basic installer	☰ > Installation Setup > CU-GH22 > Submenu ⁽¹⁾ > Parameters, counters, signals > Parameters > General ⁽²⁾
(1) See the column "Submenu" in the following table for the correct navigation. The parameters are grouped in specific functionalities.	
(2) The parameters can also be accessed directly via the Search datapoints function: ☰ > Installation Setup > Search datapoints	

Tab.68 Factory settings at basic installer level

Code	Display text	Description	Adjustment range	Submenu	35	45	65	90	115
AP016	CH function on	Enable central heating demand processing	0 = Off 1 = On	Gas fired appliance Gas Fired Appliance	1	1	1	1	1
AP017	DHW function on	Enable domestic hot water heat demand processing	0 = Off 1 = On	Gas fired appliance Gas Fired Appliance	1	1	1	1	1
AP073	Summer Winter	Outdoor temperature; Upper limit for heating	15 – 30.5 °C	Outdoor temperature	22	22	22	22	22
AP074	Force summer mode	The heating is stopped, Hot water is maintained, Force summer mode	0 = Off 1 = On	Outdoor temperature	0	0	0	0	0
AP083	Enable master func	Enable the master functionality of this device on the S-Bus for system control	0 = No 1 = Yes	Mandatory bus master Producer Manager Cascade management B Cascade management B	0	0	0	0	0
AP089	Installer name	Name of the installer		Mandatory bus master	None	None	None	None	None
AP090	Installer phone	Telephone number of the installer		Mandatory bus master	0	0	0	0	0
CP010	Tflow set-point zone	Zone flow temperature set-point, used when the zone is set to a fixed flow set-point.	25 – 90 °C	CIRCA	80	80	80	80	80
CP080 CP081 CP082 CP083 CP084 CP085	User T.Room Activity	Room setpoint temperature of the user zone activity	5 – 30 °C	CIRCA	16 20 6 21 22 20	16 20 6 21 22 20	16 20 6 21 22 20	16 20 6 21 22 20	16 20 6 21 22 20
CP200	Manu ZoneRoom-TempSet	Manually setting the room temperature setpoint of the zone	5 – 30 °C	CIRCA	20	20	20	20	20

Code	Display text	Description	Adjustment range	Submenu	35	45	65	90	115
CP320	OperatingZoneMode	Operating mode of the zone	0 = Scheduling 1 = Manual 2 = Off	CIRCA	1	1	1	1	1
CP510	Temporary Room Setp	Temporary room setpoint per zone	5 – 30 °C	CIRCA	20	20	20	20	20
CP550	Zone, fire place	Fire Place mode is active	0 = Off 1 = On	CIRCA	0	0	0	0	0
CP570	ZoneTime- Prog Select	Time Program of the zone selected by the user	0 = Schedule 1 1 = Schedule 2 2 = Schedule 3	CIRCA	0	0	0	0	0
CP660	Icon display zone	Choice icon to display this zone	0 = None 1 = All 2 = Bedroom 3 = Livingroom 4 = Study 5 = Outdoor 6 = Kitchen 7 = Basement	CIRCA	0	0	0	0	0
CP750	MaxZone Preheat time	Maximum zone preheat time	0 – 240 Min	CIRCA	0	0	0	0	0
DP045	Mix pump hysteresis	DHW mixing pump hysteresis temperature	0 – 20 °C	DHW mixing DHW Mix/ Circulation	2	2	2	2	2
DP060	DHW time-prog select	Time program selected for DHW.	0 = Schedule 1 1 = Schedule 2 2 = Schedule 3	Internal DHW	0	0	0	0	0
DP070	DHW comfort setpoint	Comfort temperature setpoint for the Domestic Hot Water tank	35 – 65 °C	Internal DHW Process heat	60	60	60	60	60
DP080	DHW eco setpoint	Eco friendly temperature setpoint from the Domestic Hot Water tank	7 – 50 °C	Internal DHW	10	10	10	10	10
DP200	DHW mode	DHW primary mode current working setting	0 = Scheduling 1 = Manual 2 = Off	Internal DHW	1	1	1	1	1
DP337	DHW holiday setpoint	Holiday temperature setpoint from the Domestic Hot Water tank	10 – 60 °C	Internal DHW	10	10	10	10	10
DP410	DHW anti-leg runtime	Duration of the DHW anti-legionella program	5 – 600 Min	Internal DHW Tank DHW layered tank	10	10	10	10	10
DP455	DHW charge pump post	The post operating time of the DHW charge pump	0 – 99 Sec	Tank DHW layered tank Process heat	15	15	15	15	15

Tab.69 Navigation for installer level

Level	Menu path
Installer	☰ > Installation Setup > CU-GH22 > Submenu ⁽¹⁾ > Parameters, counters, signals > Parameters > General ⁽²⁾
(1) See the column "Submenu" in the following table for the correct navigation. The parameters are grouped in specific functionalities.	
(2) The parameters can also be accessed directly via the Search datapoints function: ☰ > Installation Setup > Search datapoints	

Tab.70 Factory settings at installer level

Code	Display text	Description	Adjustment range	Submenu	35	45	65	90	115
AP004	Hydr valve wait time	Heat generator wait time to open the hydraulic valve	0 – 255 Sec	Gas fired appliance Gas Fired Appliance	1	1	1	1	1
AP006	Min water pressure	The appliance will report low water pressure below this value	0 – 2 bar	Gas fired appliance Gas Fired Appliance	0.4	0.4	0.4	0.4	0.4
AP009	Service hours	Number of heat generator operating hours before raising a service notification	0 – 51000 Hours	Gas fired appliance Gas Fired Appliance	8750	8750	8750	8750	8750
AP010	Service notification	Select the type of service notification	0 = None 1 = Custom notification 2 = ABC notification 3 = D notification	Gas fired appliance Gas Fired Appliance	0	0	0	0	0
AP011	Service hours mains	Hours powered to raise a service notification	0 – 51000 Hours	Gas fired appliance Gas Fired Appliance	1750 0	1750 0	1750 0	1750 0	1750 0
AP056	Outdoor sensor	Enable outdoor sensor	0 = No outdoor sensor 1 = AF60 2 = QAC34	Outdoor temperature	0	0	0	0	0
AP063	Max CH flow setpoint	Maximum central heating flow temperature setpoint	20 – 90 °C	Producer Generic Gas fired appliance Gas Fired Appliance	90	90	90	90	90
AP079	Building Inertia	Inertia of the building used for heat up speed	0 – 10	Outdoor temperature	3	3	3	3	3
AP080	Frost min out temp	Outdoor temperature below which the antifreeze protection is activated	-30 – 20 °C	Outdoor temperature	-10	-10	-10	-10	-10
AP082	Enable daylight save	Enable daylight saving for the system to save energy during winter	0 = Off 1 = On	Mandatory bus master	1	1	1	1	1
AP091	Outdoor sensors source	Type of outdoor sensor connection to be used	0 = Auto 1 = Wired sensor 2 = Wireless sensor 3 = Internet measured 4 = None	Outdoor temperature	0	0	0	0	0

Code	Display text	Description	Adjustment range	Submenu	35	45	65	90	115
AP178	Pump output profile	Output profile of the 0-10V/PWM pump	0 = 0-10V 1 (Wilo) 1 = 0-10V 2 (Gr GENI) 2 = PWM signal (Solar) 3 = 0-10V 1 limited 4 = 0-10V 2 limited 5 = PWM signal limited 6 = PWM signal (UPMXL)	Pump Configuration	0	0	0	0	0
CP000	MaxZoneT-FlowSetpoint	Maximum Flow Temperature setpoint zone	25 – 90 °C	CIRCA	80	80	80	80	80
CP020	Zone Function	Functionality of the zone	0 = Disable 1 = Direct	CIRCA	1	1	1	1	1
CP060	Room T holiday	Wished room zone temperature on holiday period	5 – 20 °C	CIRCA	6	6	6	6	6
CP070	MaxReducedRoomT.Lim	Max Room Temperature limit of the circuit in reduced mode, that allows switching to comfort mode	5 – 30 °C	CIRCA	16	16	16	16	16
CP210	Zone HCZP Comfort	Comfort footpoint of the temperature of heat curve of the circuit	15 – 90 °C	CIRCA	15	15	15	15	15
CP220	Zone HCZP Reduced	Reduced footpoint of the temperature of heat curve of the circuit	15 – 90 °C	CIRCA	15	15	15	15	15
CP230	Zone Heating Curve	Heating curve temperature gradient of the zone	0 – 4	CIRCA	1.5	1.5	1.5	1.5	1.5
CP240	ZoneRoomUnitInfl	Adjustment of the influence of the zone room unit	0 – 10	CIRCA	3	3	3	3	3
CP250	Calibration sensor	Adjust the measured room temperature	-5 – 5 °C	CIRCA	0	0	0	0	0
CP340	TypeReducedNight-Mode	Type of reduced night mode, stop or maintain heating of circuit	0 = Stop heat demand 1 = Continue heat demand	CIRCA	1	1	1	1	1
CP730	Zone Heat up speed	Selection of heat up speed of the zone	0 = Extra Slow 1 = Slowest 2 = Slower 3 = Normal 4 = Faster 5 = Fastest	CIRCA	3	3	3	3	3
CP740	Zone cool down speed	Selection of cool down speed of the zone	0 = Slowest 1 = Slower 2 = Normal 3 = Faster 4 = Fastest	CIRCA	2	2	2	2	2
CP780	Control strategy	Selection of the control strategy for the zone	0 = Automatic 1 = Room temp based 2 = Outdoor temp based 3 = Outdoor & room based	CIRCA	0	0	0	0	0
DP024	Mix anti-leg mode	DHW mixing pump anti- legionella mode	0 = Off 1 = During charging 2 = Charging + disinfect	DHW mixing DHW Mix/ Circulation	0	0	0	0	0

Code	Display text	Description	Adjustment range	Submenu	35	45	65	90	115
DP025	DHW mixing pump	DHW mixing pump enable	0 = Off 1 = On	DHW mixing DHW Mix/ Circulation	0	0	0	0	0
DP026	Delta DHW tank temp	Maximum temperature difference between the top and bottom of the DHW tank	0 – 100 °C	DHW mixing DHW Mix/ Circulation	6	6	6	6	6
DP035	Start pump DHW calo	Start pump for Domestic Hot Water calorifier	-20 – 20 °C	Tank DHW DHW layered tank	-3	-3	-3	-3	-3
DP044	Min DHW tank temp	Minimum bottom temperature DHW tank	0 – 120 °C	DHW mixing DHW Mix/ Circulation	70	70	70	70	70
DP049	DHW tank mixing	Enable/disable domestic hot water tank mixing	0 = Off 1 = On	DHW mixing DHW Mix/ Circulation	0	0	0	0	0
DP050	Circulation mode	DHW circulation pump mode selection	0 = Pump is off 1 = Pump on time program 2 = Pump for DHW comfort	DHW circulation DHW Mix/ Circulation	0	0	0	0	0
DP052	Circ pump on time	DHW circulation pump cyclic ON time	0 – 20 Min	DHW circulation DHW Mix/ Circulation	0	0	0	0	0
DP053	Circ pump off time	DHW circulation pump cyclic OFF time	0 – 20 Min	DHW circulation DHW Mix/ Circulation	0	0	0	0	0
DP054	Circ pump anti leg	DHW circulation pump anti legionella	0 = Off 1 = On	DHW circulation DHW Mix/ Circulation	0	0	0	0	0
DP057	Circulation Toffset	DHW circulation offset temperature	0 – 20 °C	DHW circulation DHW Mix/ Circulation	0	0	0	0	0
DP150	DHW Thermostat	Enable DHW Thermostat function	0 = Off 1 = On	Tank DHW Process heat	1	1	1	1	1

Code	Display text	Description	Adjustment range	Submenu	35	45	65	90	115
DP160	DHW Anti-Leg Setpoint	Setpoint for DHW anti legionella	60 – 90 °C	Internal DHW Tank DHW DHW layered tank	65	65	65	65	65
DP336	DHW pump hysteresis	DHW circulation pump hysteresis temperature	1 – 60 °C	DHW circulation DHW Mix/ Circulation	6	6	6	6	6
DP430	Start day anti-leg	Day to start the DHW anti-legionella program	1 = Monday 2 = Tuesday 3 = Wednesday 4 = Thursday 5 = Friday 6 = Saturday 7 = Sunday	Internal DHW Tank DHW DHW layered tank	6	6	6	6	6
DP440	Start time anti-leg	Starting time for the DHW anti-legionella program	0 – 143 HoursMinutes	Internal DHW Tank DHW DHW layered tank	18	18	18	18	18
DP450	DHW circulation	DHW circulation zone enabled	0 = Off 1 = On	DHW circulation DHW Mix/ Circulation	0	0	0	0	0
DP452	DHW priority	Selects the DHW priority	0 = Total 1 = Relative 2 = None	Tank DHW DHW layered tank	0	0	0	0	0
DP473	Circulation Tsensor	DHW circulation temperature sensor connected	0 = No 1 = Yes	DHW circulation DHW Mix/ Circulation	1	1	1	1	1
EP014	SCB func 10V PWMIn	Smart Control Board function 10 Volt PWM input	0 = Off 1 = Temperature control 2 = Power control	0-10 volt input	0	0	0	0	0
EP030	Min Setp Temp 0-10V	Sets the minimum setpoint temperature for 0 - 10 volts for the Smart Control Board	0 – 100 °C	0-10 volt input	0	0	0	0	0
EP031	Max Setp Temp 0-10V	Sets the maximum setpoint temperature for 0 - 10 volts for the Smart Control Board	0.5 – 100 °C	0-10 volt input	100	100	100	100	100
EP032	Min Setp Power 0-10V	Sets the minimum setpoint power for 0 - 10 volts for the Smart Control Board	0 – 100 %	0-10 volt input	0	0	0	0	0
EP033	Max Setp Power 0-10V	Sets the maximum setpoint power for 0 - 10 volts	5 – 100 %	0-10 volt input	100	100	100	100	100
EP034	Min Setp Volt 0-10V	Sets the minimum setpoint voltage for 0 - 10 volts for the Smart Control Board	0.5 – 10 V	0-10 volt input	0.5	0.5	0.5	0.5	0.5
EP035	Max Setp Volt 0-10V	Sets the maximum setpoint voltage for 0 - 10 volts	0 – 10 V	0-10 volt input	10	10	10	10	10

Code	Display text	Description	Adjustment range	Submenu	35	45	65	90	115
GP094	Chimney sweep power	Custom power setpoint for the chimney sweep mode	0 – 100 %	Gas fired appliance	50	50	50	50	50
NP005	Cascade Permutation	Choice of the leading generator, Default = Switching of order every 7 days	0 – 127	Cascade management B Cascade management B	0	0	0	0	0
NP006	Cascade Type	Cascading boilers by adding successively or in parallel, the boilers function simultaneously	0 = Traditional 1 = Parallel	Cascade management B Cascade management B	0	0	0	0	0
NP007	CascTOutdoorHeatParl	Outdoor start temperature heating of all stages in parallel mode	-10 – 20 °C	Cascade management B Cascade management B	10	10	10	10	10
NP008	CascPrimPumpPostRun	Duration of post operation of the cascade primary circulation pump	0 – 30 Min	Cascade management B Cascade management B	4	4	4	4	4
NP009	CascInterStageTime	Switch on and switch off timing for the producer of the cascade	1 – 60 Min	Cascade management B Cascade management B	10	10	10	10	10
NP010	CascTOutdoorCoolPara	Outdoor start temperature cooling of all stages in parallel mode	10 – 40 °C	Cascade management B Cascade management B	30	30	30	30	30
NP011	Cascade algorithm	Type of cascade management which is requested.	0 = Temperature 1 = Power	Cascade management B Cascade management B	0	0	0	0	0
NP012	CascPowerRiseTime	Cascade, Time to reach Temperature Setpoint	1 – 10	Cascade management B Cascade management B	1	1	1	1	1
NP013	CascForceStopPprim	Force Primary Pump to Stop on cascade	0 = No 1 = Yes	Cascade management B Cascade management B	0	0	0	0	0

Code	Display text	Description	Adjustment range	Submenu	35	45	65	90	115
NP014	Cascade Mode	Functionnement mode of cascade; Automatic, heating or cooling	0 = Automatic 1 = Heating 2 = Cooling	Cascade management B Cascade management B	0	0	0	0	0
PP015	CH Pump postrun time	Central heating pump post-run time	1 – 99 Min	Gas fired appliance Gas Fired Appliance	3	3	3	3	3

Tab.71 Navigation for advanced installer level

Level	Menu path
Advanced installer	☰ > Installation Setup > CU-GH22 > Submenu ⁽¹⁾ > Parameters, counters, signals > Parameters > Advanced ⁽²⁾
<p>(1) See the column "Submenu" in the following table for the correct navigation. The parameters are grouped in specific functionalities. (2) The parameters can also be accessed directly via the Search datapoints function: ☰ > Installation Setup > Search datapoints</p>	

Tab.72 Factory settings at advanced installer level

Code	Display text	Description	Adjustment range	Submenu	35	45	65	90	115
AP002	Manual Heat Demand	Enable manual heat demand function	0 = Off 1 = With setpoint	Gas fired appliance Gas Fired Appliance	0	0	0	0	0
AP026	Setpoint manual HD	Flow temperature setpoint for manual heat demand	7 – 90 °C	Gas fired appliance Gas Fired Appliance	40	40	40	40	40
AP061	Max corr system sens	Maximum system temperature correction when a system temperature sensor is available	0 – 20 °C	DHWE iAB Multifunct sensors Gas fired appliance	10	10	10	10	10
AP062	P-factor system sens	P-factor (gain factor) for the system temperature correction	0.5 – 5	DHWE iAB Multifunct sensors Gas fired appliance	1	1	1	1	1
AP102	Appliance pump funct	Configuration of the appliance pump as zone pump or system pump (feed low-loss header)	0 = No 1 = Yes	Gas fired appliance Gas Fired Appliance	0	0	0	0	0
AP153	parA-pCfgOutput-PinFun	parApCfgOutputPinFunction	0 – 2	Gas Fired Appliance	0	0	0	0	0
AP173	Pump control	Pump control signal/comms types	0 = LIN pump 1 = PWM pump 2 = PWM/0-10V profiles 3 = On/Off pump control	Pump Configuration	1	1	1	1	1

Code	Display text	Description	Adjustment range	Submenu	35	45	65	90	115
AP200	Temperature setpoint	Temperature setpoint requested when the input is active	0.7 – 100 °C	Multi-functional in	90	90	90	90	90
AP201	Temperature setpoint	Temperature setpoint requested when the input is active	0.7 – 100 °C	Multi-functional in	90	90	90	90	90
CP450	Pump type	The connected pump type	0 = On/Off 1 = Modulating PWM 2 = Modulating LIN	CIRCA	1	1	1	1	1
CP680	ConfPairing RU Zone	Select the Bus channel of the room unit for this zone	0 – 1	CIRCA	0	0	0	0	0
CP850	Hydronic balancing	Hydronic balancing operation possible	0 = No 1 = Yes	CIRCA	0	0	0	0	0
DP003	Abs max fan DHW	Maximum fan speed on Domestic Hot Water	1400 – 7500 Rpm	Gas fired appliance Gas Fired Appliance GVC Generic	4700	5400	5600	6300	6800
DP004	Anti-legionella	Anti-legionella protection of the calorifier	0 = Disabled 1 = Weekly 2 = Daily	Internal DHW Tank DHW DHW layered tank	1	1	1	1	1
DP005	Calorifier Tf offset	Flow setpoint offset for loading calorifier	0 – 50 °C	Tank DHW DHW layered tank Process heat	20	20	20	20	20
DP006	Hyst calorifier	Hysteresis to start heating calorifier	2 – 15 °C	Tank DHW DHW layered tank Process heat	5	5	5	5	5
DP007	Dhw 3wv Standby	Position of three way valve during standby	0 = CH position 1 = DHW position	Tank DHW DHW layered tank Process heat	0	0	0	0	0
DP010	Hysteresis DHW	Temperature hysteresis for the heat generator to start on domestic hot water production	0.2 – 10 °C	Process heat Gas fired appliance Gas Fired Appliance	5.5	5.5	5.5	5.5	5.5
DP011	Stop offset DHW	Temperature offset to stop heat generator on domestic hot water production	0 – 20 °C	Tank DHW DHW layered tank Process heat Gas fired appliance Gas Fired Appliance	5	5	5	5	5

Code	Display text	Description	Adjustment range	Submenu	35	45	65	90	115
DP020	Postrun DHW pump/3wv	Post run time of the DHW pump/3 way valve after DHW production	0 – 180 Sec	Gas fired appliance Gas Fired Ap- pliance	10	10	10	10	10
DP034	DhwCalori- fierOffset	Offset for calorifier sensor	0 – 10 °C	Tank DHW DHW lay- ered tank Process heat	2	2	2	2	2
DP140	DHW load type	DHW load type (0 = Combi, 1 = Solo)	1 = Solo 2 = Layered cylinder 3 = Process heat	Internal DHW Tank DHW DHW lay- ered tank Process heat Gas fired appliance Gas Fired Ap- pliance	1	1	1	1	1
DP474	DHW cylin- der as zone	Domestic hot water cylinder connected as zone	0 = No 1 = Yes	Tank DHW DHW lay- ered tank Process heat	0	0	0	0	0
DP480	Pump on when DHW	Turn the pump on immedi- ately for DHW heat demand	0 = No 1 = Yes	Tank DHW DHW lay- ered tank Process heat	1	1	1	1	1
DP481	Enable DHW top temp	Enable the top temperature sensor of the DHW tank	0 = No 1 = Yes	DHW lay- ered tank	0	0	0	0	0
GP007	Fan RPM Max CH	Maximum fan speed during Central Heating mode	1400 – 7500 Rpm	Gas fired appliance Gas Fired Ap- pliance GVC Ge- neric	4700	5400	5600	6300	6800
GP008	Fan RPM Min	Minimum fan speed during Central Heating + Domestic Hot Water mode	1000 – 4000 Rpm	Gas fired appliance Gas Fired Ap- pliance GVC Ge- neric	1550	1550	1600	1600	1800
GP009	Fan RPM Start	Fan speed at appliance start	900 – 5000 Rpm	Gas fired appliance Gas Fired Ap- pliance GVC Ge- neric	2500	2500	2500	2500	2500

Code	Display text	Description	Adjustment range	Submenu	35	45	65	90	115
GP010	GPS Check	Gas Pressure Switch check on/off	0 = No 1 = Yes	Gas fired appliance Gas Fired Appliance	0	0	0	0	0
GP017	Max power	Maximum power percentage in kilo Watt	0 – 800 kW	Gas fired appliance Gas Fired Appliance	56.9	59.2	85.7	104.2	119.2
GP021	Temp diff Modulating	Modulate back when delta temperature is larger than this threshold	5 – 45 °C	Gas fired appliance Gas Fired Appliance	25	25	25	25	20
GP050	Power min	Minimum power in kilo Watt for RT2012 calculation	0 – 80 kW	Gas fired appliance Gas Fired Appliance	3.7	3.5	4.7	5.5	5.6
GP082	Chimney over DHW	Enable the DHW circuit during chimney sweep	0 = Off 1 = On	Gas fired appliance Gas Fired Appliance	0	0	0	0	0
NP001	CascProd-Man Hys.High	Hysteresis high for Producer Manager	0.5 – 10 °C	Cascade management B Cascade management B	3	3	3	3	3
NP002	CascProd-Man Hys.Low	Hysteresis low for Producer Manager	0.5 – 10 °C	Cascade management B Cascade management B	3	3	3	3	3
NP003	CascProd-ManErr-Range	Maximum error gain for Producer Manager	0 – 10 °C	Cascade management B Cascade management B	10	10	10	10	10
NP004	CascPFactorAlgoTemp	Proportional Factor for cascade with Temperature algorithm	0 – 10	Cascade management B Cascade management B	1	1	1	1	1
PP007	Min anti-cycle time	Minimum heat generator holding time that can be reached after a stop	1 – 20 Min	Gas fired appliance Gas Fired Appliance	3	3	3	3	3
PP012	Stabilization time	Stabilization time after heat generator start for central heating	0 – 180 Sec	Gas fired appliance Gas Fired Appliance	30	30	30	30	30

Code	Display text	Description	Adjustment range	Submenu	35	45	65	90	115
PP014	ChPumpD-TReduction	Reduction of temperature delta modulating for pump modulation	0 – 40 °C	Gas fired appliance Gas Fired Appliance	18	18	18	18	18
PP016	Max CH pump speed	Maximum central heating pump speed (%)	20 – 100 %	Gas fired appliance Gas Fired Appliance	100	100	100	100	100
PP018	Min CH pump speed	Minimum central heating pump speed (%)	20 – 100 %	Gas fired appliance Gas Fired Appliance	30	30	30	30	30
PP023	CH Hysteresis	Temperature hysteresis for the generator to start on central heating	1 – 25 °C	Gas fired appliance Gas Fired Appliance	10	10	10	10	10
PP039	Stop heating offset	Temperature offset to stop heat generator on central heating	0 – 10 °C	Gas Fired Appliance	5	5	5	5	5
ZP000	Screed drying time 1	Set the number of days spent in the first screed drying step	0 – 30 Days	Direct zone	3	3	3	3	3
ZP010	Screed start temp 1	Set the start temperature for the first step of screed drying	7 – 60 °C	Direct zone	20	20	20	20	20
ZP020	Screed end temp 1	The end temperature for the first step of screed drying	7 – 60 °C	Direct zone	32	32	32	32	32
ZP030	Screed drying time 2	Set the number of days spent in the second screed drying step	0 – 30 Days	Direct zone	11	11	11	11	11
ZP040	Screed start temp 2	Set the start temperature for the second step of screed drying	7 – 60 °C	Direct zone	32	32	32	32	32
ZP050	Screed end temp 2	The end temperature for the second step of screed drying	7 – 60 °C	Direct zone	32	32	32	32	32
ZP060	Screed drying time 3	Set the number of days spent in the third screed drying step	0 – 30 Days	Direct zone	2	2	2	2	2
ZP070	Screed start temp 3	Set the start temperature for the third step of screed drying	7 – 60 °C	Direct zone	32	32	32	32	32
ZP080	Screed end temp 3	The end temperature for the third step of screed drying	7 – 60 °C	Direct zone	24	24	24	24	24
ZP090	Screed drying enable	Enable the screed drying of the zone	0 = Off 1 = On	Direct zone	0	0	0	0	0

9 Maintenance

9.1 Maintenance regulations



Danger of electric shock
High voltages

Risk of electric shock.

- Always disconnect the mains power supply before working on the appliance.



Danger
Gas leakage

Chance of explosion.

- Always close the main gas tap when working on the appliance.



Danger
Leakage

Risk of poisoning, explosion and material damage.

- Always replace all gaskets on the parts removed.
- Make sure that all gaskets have been positioned properly.
- Check the entire system for leaks after maintenance and servicing work.



Warning
Hazardous appliance

Chance of injury for unqualified users.

- Only remove the casing panels for maintenance and repair operations.
- Refit all panels immediately when the work is complete.



Warning
Component incompatibility

Dangerous situations due to mismatching components.

- Use only genuine spare parts.



Caution
Harmful dust particles

Risk of eye damage or inhalation of harmful particles.

- Always wear safety goggles and a dust mask when working with compressed air.



Notice
Water leakage

Damaged components due to leaking water.

- Never allow water to come into contact with electrical parts.



Important

- Perform the standard checking and maintenance procedures once a year.
- Perform the specific maintenance procedures if necessary.



Important

Adjust the frequency of inspection and service to the conditions of use, especially if the appliance is:

- In constant use (for example as process heat).
- Used with a low supply temperature.
- Used with a high ΔT .

9.2 Preparation

Carry out the following steps before commencing inspection and maintenance activities:

1. Set the boiler to full load until the return temperature is around 65 °C, to dry the heat exchanger on the flue gas side.

2. Check the water pressure.
The minimum water pressure is 0.8 bar. The recommended water pressure is between 1.5 bar and 2.0 bar.
 - 2.1. If necessary, top up the central heating system.
3. Check the ionisation current at full load and at low load.
The value is stable after 1 minute.
 - 3.1. If the value is lower than 4 μ A, clean or replace the ionisation and ignition electrode.
4. Check the condition and tightness of the flue gas outlet and air supply system.
5. Check the combustion by measuring the O₂ percentage in the flue gasses.

**Important**

- This appliance is suitable for category I_{2E} and I_{2Esi} and I_{2H} containing up to 20% Hydrogen gas (H₂). Due to variations in the H₂ percentage, the O₂ percentage can vary over time. (For example: a percentage of 20% H₂ in the gas can lead to an increase of 1,5% of O₂ in the flue gasses)
- A significant adjustment of the gas valve may be needed. Adjustment can be done using the standard O₂ values of the gas used.

**See also**

Checking and setting the gas/air ratio, page 50

9.3 Opening the boiler

Fig.109 Removing the panel

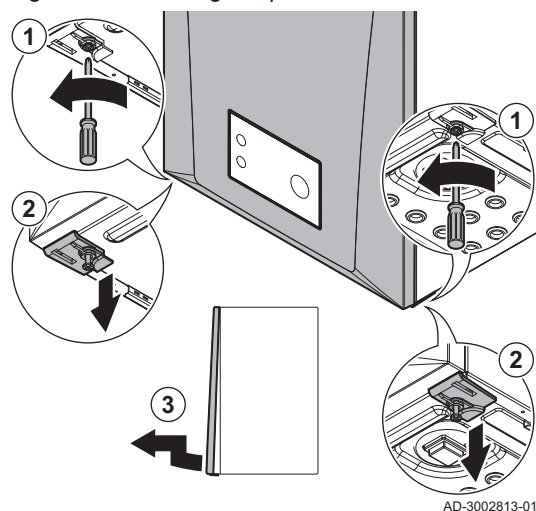

1. Unscrew the two screws by a quarter turn.
2. Unlock the two clips.
3. Remove the panel.

9.4 Standard inspection and maintenance operations

For a service, always perform the following standard inspection and maintenance operations.

**See**

The service manual for the specific maintenance work. This manual can be found on the website.

9.4.1 Checking the water quality

**Notice****Water quality**

Damage to the product.
Warranty void.

- Make sure the water quality requirements are fulfilled.

1. Fill a clean bottle with some water from the system (connected to the boiler).

2. Check the quality of this water sample or have it checked.

9.4.2 Cleaning the trap

Danger
Flue gas leakage
 Chance of CO poisoning.

- Make sure the trap is sufficiently filled with water.

Fig.110 Cleaning the trap

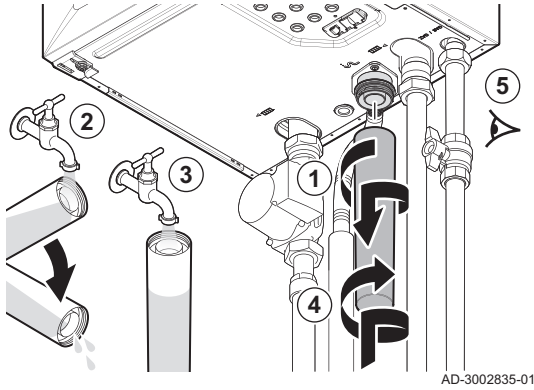

1. Remove the trap.
2. Clean the trap with water.
3. Fill the trap with water.
4. Fit the trap.
5. Check for leaks.

9.5 Finalising work

1. Fit all removed parts in the reverse order, but do not close the casing yet.

Danger
Leakage
 Risk of poisoning, explosion and material damage.

- Always replace all gaskets on the parts removed.
- Make sure that all gaskets have been positioned properly.
- Check the entire system for leaks after maintenance and servicing work.

2. Fill the trap with water.
3. Put the trap back in place.
4. Carefully open all system and supply valves which were closed to carry out the maintenance.
5. Fill the central heating system with water if necessary.
6. Vent the central heating system.
7. Top up with more water if necessary.
8. Check the tightness of the gas and water connections.
9. Put the boiler back into operation.
10. Carry out an auto-detect when a control board has been replaced or removed from the boiler.
11. Set the boiler to full load and carry out a gas leak detection and a thorough visual check.
12. Set the boiler to normal operation.
13. Close the casing.

9.6 Disposal and recycling

Fig.111 For all countries apart from France



Important
 Removal and disposal of the appliance must be carried out by a qualified person in accordance with local and national regulations.

Fig.112 For France



MW-1002249-1

9.6.1 Removal

To remove the boiler, proceed as follows:

1. Cut the power supply to the boiler.
2. Shut off the gas supply.
3. Shut off the water supply.
4. Drain the system.
5. Remove the trap.
6. Remove the air supply/flue gas outlet pipes.
7. Disconnect all pipes on the boiler.
8. Remove the boiler.

10 Troubleshooting

10.1 Error codes

The AMC PRO EVO is fitted with an electronic regulation and control unit. The heart of the control is a microprocessor, which controls and also protects. In the event of an error, a corresponding code is displayed.

Tab.73 Error codes are displayed at three different levels

Code	Type	Description
A .00.00 ⁽¹⁾	Warning	The controls continue to operate, but the cause of the warning must be investigated. A warning can change into a blocking or lock-out.
H .00.00 ⁽¹⁾	Blocking	The controls will stop normal operation, and will check with set intervals if the cause of the blocking still exists. ⁽²⁾ Normal operation will resume when the cause of the blocking has been rectified. A blocking can become a lock-out.
E .00.00 ⁽¹⁾	Lock out	The controls will stop normal operation. The cause of the lock-out must be rectified and the controls must be reset manually.

(1) The first letter indicates the type of error.
 (2) For some blocking errors, this checking interval is ten minutes. In those cases, it may seem that the controls do not start automatically. Wait ten minutes before resetting.

The meaning of the code can be found in the various error code tables.



Important

The error code is needed to find the cause of the error quickly and correctly and for any support from De Dietrich.

10.1.1 Display of error codes

When an error occurs in the installation, the control panel will show the following:

Fig.113 Error code display on Diematic Evolution

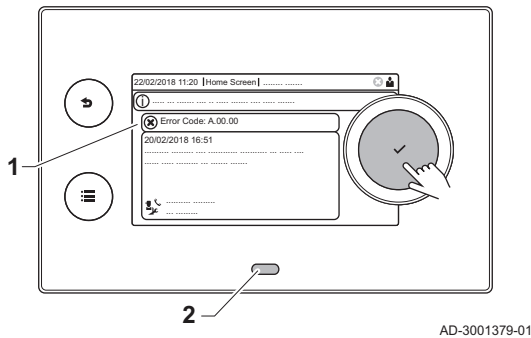

- 1 The display will show a corresponding code and message.
- 2 The status LED of the control panel will show:
 - Continuous green = Normal operation
 - Flashing green = Warning
 - Continuous red = Blocking
 - Flashing red = Lock out

When an error occurs, proceed as follows:

1. Press and hold the ✓ button to reset the appliance.

i Important
 You can reset the appliance for a maximum of 10 times. After that the appliance will be blocked for one hour. Do a restart (disconnect the power) to avoid the one hour delay.

⇒ The appliance starts up again.

2. If the error code reappears, correct the problem by following the instructions in the error code tables.

i Important
 Only qualified professionals are authorised to work on the appliance and system.

⇒ The error code remains visible until the problem is solved.

3. Note the error code when the problem cannot be resolved.
4. Contact your installer or De Dietrich for support.

10.1.2 Warning

Tab.74 Warning codes

Code	Display text	Description	Solution
A.00.32	TOutdoor Open	Outdoor temperature sensor is either removed or measures a temperature below range	Outdoor temperature sensor open: <ul style="list-style-type: none"> • Bad connection: check the wiring and connectors • Incorrectly fitted sensor: check that the sensor has been correctly fitted • Sensor is not present. • Faulty sensor: replace the sensor
A.00.33	TOutdoor Closed	Outdoor temperature sensor is either shorted or measures a temperature above range	Outdoor temperature sensor short-circuited: <ul style="list-style-type: none"> • Bad connection: check the wiring and connectors • Incorrectly fitted sensor: check that the sensor has been correctly fitted • Faulty sensor: replace the sensor
A.00.34	TOutdoor Missing	Outdoor temperature sensor was expected but not detected	Outdoor sensor not detected: <ul style="list-style-type: none"> • Outdoor sensor is not connected: Connect the sensor • Outdoor sensor is not connected correctly: Connect the sensor correctly
A.00.40	Water pressure low	Measured water pressure is below the defined range. Verify water pressure and sensor	No valid water pressure detected: <ul style="list-style-type: none"> • Water pressure sensor is not connected: Connect the sensor. • Water pressure sensor measured a value below range: Check the water connection of the appliance.

Code	Display text	Description	Solution
A.00.57	T DHW Top Open	Domestic Hot Water top temperature sensor is either removed or measures a temperature below range	DHW is configured as a layered cylinder with 2 sensors. An open connection was detected on the DHW cylinder top temperature sensor: <ul style="list-style-type: none"> • Bad connection: Check the wiring and connectors. • Incorrectly fitted sensor: Check that the sensor has been correctly fitted. • Faulty sensor: Replace the sensor. • No sensor is present: Make sure that parameter DP481 is set to No (0).
A.00.58	T DHW Top Closed	Domestic Hot Water top temperature sensor is either shorted or measures a temperature above range	DHW is configured as a layered cylinder with 2 sensors. A short circuit was detected on the DHW cylinder top temperature sensor: <ul style="list-style-type: none"> • Bad connection: Check the wiring and connectors. • Incorrectly fitted sensor: Check that the sensor has been correctly fitted. • Faulty sensor: Replace the sensor. • No sensor is present: Make sure that parameter DP481 is set to No (0).
A.00.107	Tdhw bottom closed	DHW bottom cylinder temperature sensor is either shorted or measures a temperature above range	A short circuit was detected on the DHW cylinder bottom temperature sensor: <ul style="list-style-type: none"> • Bad connection: Check the wiring and connectors. • Incorrectly fitted sensor: Check that the sensor has been correctly fitted. • Faulty sensor: Replace the sensor.
A.00.108	Tdhw bottom open	DHW bottom cylinder temperature sensor is either removed or measures a temperature below range	An open connection was detected on the DHW cylinder bottom temperature sensor: <ul style="list-style-type: none"> • Bad connection: Check the wiring and connectors. • Incorrectly fitted sensor: Check that the sensor has been correctly fitted. • Faulty sensor: Replace the sensor.
A.01.23	Poor Combustion	Poor combustion	Configuration error: No flame during operation: <ul style="list-style-type: none"> • No ionisation current: <ul style="list-style-type: none"> - Purge the gas supply to remove air. - Check whether the gas tap is properly open. - Checking the gas supply pressure. - Check the operation and setting of the gas valve unit. - Check that the air inlet and flue gas discharge flues are not blocked. - Check that there is no recirculation of flue gases.
A.02.06	Water Press Warning	Water Pressure Warning active	Water pressure warning: <ul style="list-style-type: none"> • Water pressure too low; check the water pressure
A.02.18	OBD Error	Object Dictionary Error	Configuration error: <ul style="list-style-type: none"> • Reset CN1 and CN2  See The data plate for the CN1 and CN2 values.
A.02.36	Funcnt device lost	Functional device has been disconnected	SCB not found: <ul style="list-style-type: none"> • Bad connection: check the wiring and connectors • Faulty SCB: Replace SCB

Code	Display text	Description	Solution
A.02.37	Uncritic device lost	Uncritical device has been disconnected	SCB not found: <ul style="list-style-type: none"> • Bad connection: check the wiring and connectors • Faulty SCB: Replace SCB
A.02.45	Full Can Conn Matrix	Full Can Connection Matrix	SCB not found: <ul style="list-style-type: none"> • Carry out an auto-detect
A.02.46	Full Can Device Adm	Full Can Device Administration	SCB not found: <ul style="list-style-type: none"> • Carry out an auto-detect
A.02.49	Failed Init Node	Failed Initialising Node	SCB not found: <ul style="list-style-type: none"> • Carry out an auto-detect
A.02.55	Inval or miss SerNR	Invalid or missing device serial number	Contact your supplier.
A.02.69	Fair mode active	Fair mode active	Contact your supplier.
A.02.76	Memory full	The reserved space in memory for custom parameters value is full. No more user changed possible	Configuration error: <ul style="list-style-type: none"> • Reset CN1 and CN2 • Faulty CSU: Replace CSU • Replace the CU-GH
A.02.80	Missing Cascade Ctrl	Missing Cascade controller	Cascade controller not found: <ul style="list-style-type: none"> • Reconnect the cascade master • Carry out an auto-detect
A.08.06	LIN pump 1 warning	LIN pump 1 warning operating on limited conditions	LIN pump 1 operating on limited conditions: <p> See See LIN pump troubleshooting for solutions</p>
A.10.33	SDhwTopZoneD Open	Domestic Hot Water tank top temperature sensor Zone DHW open	Domestic hot water top temperature sensor open: <ul style="list-style-type: none"> • Bad connection: check the wiring and connectors • Incorrectly fitted sensor: check that the sensor has been correctly fitted • Sensor is not present. • Faulty sensor: replace the sensor
A.10.34	SDhwTopZoneD Closed	Domestic Hot Water tank top temperature sensor Zone DHW Closed	Domestic hot water top temperature sensor short-circuited: <ul style="list-style-type: none"> • Bad connection: check the wiring and connectors • Incorrectly fitted sensor: check that the sensor has been correctly fitted • Faulty sensor: replace the sensor
A.10.45	RoomTempZoneA miss	Measure of Room Temperature Zone A is missing	Room temperature sensor not detected in zone A: <ul style="list-style-type: none"> • Room temperature sensor is not connected: connect the sensor • Room temperature sensor is not connected correctly: connect the sensor correctly • Faulty sensor: replace the sensor
A.10.46	RoomTempZoneB miss	Measure of Room Temperature Zone B is missing	Room temperature sensor not detected in zone B: <ul style="list-style-type: none"> • Room temperature sensor is not connected: connect the sensor • Room temperature sensor is not connected correctly: connect the sensor correctly • Faulty sensor: replace the sensor

Code	Display text	Description	Solution
A.10.47	RoomTempZoneC miss	Measure of Room Temperature Zone C is missing	Room temperature sensor not detected in zone C: <ul style="list-style-type: none"> Room temperature sensor is not connected: connect the sensor Room temperature sensor is not connected correctly: connect the sensor correctly Faulty sensor: replace the sensor
A.10.50	T_DHW top D miss	Domestic Hot Water temperature sensor top zone DHW is missing	Domestic hot water temperature sensor not detected in zone DHW: <ul style="list-style-type: none"> Domestic hot water temperature sensor is not connected: connect the sensor Domestic hot water temperature sensor is not connected correctly: connect the sensor correctly Faulty sensor: replace the sensor
A.10.54	Temp zone DHW miss	Temperature sensor Zone DHW is missing	Temperature sensor not detected in zone DHW: <ul style="list-style-type: none"> Temperature sensor is not connected: connect the sensor Temperature sensor is not connected correctly: connect the sensor correctly Faulty sensor: replace the sensor
A.10.56	T_DHW Zone AUX miss	Domestic Hot Water temperature sensor Zone AUX is missing	Domestic hot water temperature sensor not detected in zone AUX: <ul style="list-style-type: none"> Domestic hot water temperature sensor is not connected: connect the sensor Domestic hot water temperature sensor is not connected correctly: connect the sensor correctly Faulty sensor: replace the sensor

10.1.3 Blocking

Tab.75 Blocking codes

Code	Display text	Description	Solution
H.00.69	TbufferTankOpen	Buffer Tank temperature sensor is either removed or measures a temperature below range	Buffer tank temperature sensor open: <ul style="list-style-type: none"> Bad connection: check the wiring and connectors Incorrectly fitted sensor: check that the sensor has been correctly fitted Sensor is not present. Faulty sensor: replace the sensor
H.00.70	TbufferTankClosed	Buffer Tank temperature sensor is either shorted or measures a temperature above range	Buffer tank temperature sensor short-circuited: <ul style="list-style-type: none"> Bad connection: check the wiring and connectors Incorrectly fitted sensor: check that the sensor has been correctly fitted Faulty sensor: replace the sensor
H.00.71	TbufferTankTopOpen	Buffer Tank top temperature sensor is either removed or measures a temperature below range	Buffer tank top temperature sensor open: <ul style="list-style-type: none"> Bad connection: check the wiring and connectors Incorrectly fitted sensor: check that the sensor has been correctly fitted Sensor is not present. Faulty sensor: replace the sensor

Code	Display text	Description	Solution
H.00.72	TbufferTankTopClosed	Buffer Tank top temperature sensor is either shorted or measures a temperature above range	Buffer tank top temperature sensor short-circuited: <ul style="list-style-type: none"> • Bad connection: check the wiring and connectors • Incorrectly fitted sensor: check that the sensor has been correctly fitted • Faulty sensor: replace the sensor
H.00.74	TBufferTankMissing	Buffer Tank temperature sensor was expected but not detected	Buffer tank temperature sensor not detected: <ul style="list-style-type: none"> • Buffer tank temperature sensor is not connected: Connect the sensor • Buffer tank temperature sensor is not connected correctly: Connect the sensor correctly • Faulty sensor: replace the sensor
H.00.75	TBufferTankTop Miss	Buffer Tank Top temperature sensor was expected but not detected	Buffer tank top temperature sensor not detected: <ul style="list-style-type: none"> • Buffer tank top temperature sensor is not connected: Connect the sensor • Buffer tank top temperature sensor is not connected correctly: Connect the sensor correctly
H.00.76	TcascadeFlow Open	Cascade Flow temperature sensor is either removed or measures a temperature below range	Cascade flow temperature sensor open: <ul style="list-style-type: none"> • Bad connection: check the wiring and connectors • Incorrectly fitted sensor: check that the sensor has been correctly fitted • Sensor is not present. • Faulty sensor: replace the sensor
H.00.77	TcascadeFlow Closed	Cascade Flow temperature sensor is either shorted or measures a temperature above range	Cascade flow temperature sensor short-circuited: <ul style="list-style-type: none"> • Bad connection: check the wiring and connectors • Incorrectly fitted sensor: check that the sensor has been correctly fitted • Faulty sensor: replace the sensor
H.00.78	TcascadeFlow missing	Cascade Flow temperature sensor was expected but not detected	Cascade flow temperature sensor not detected: <ul style="list-style-type: none"> • Cascade flow temperature sensor is not connected: Connect the sensor • Cascade flow temperature sensor is not connected correctly: Connect the sensor correctly • Faulty sensor: replace the sensor
H.00.81	RoomTempMissing	Room Temperature sensor was expected but not detected	Room temperature sensor not detected: <ul style="list-style-type: none"> • Room temperature sensor is not connected: Connect the sensor • Room temperature sensor is not connected correctly: Connect the sensor correctly
H.01.00	Comm Error	Communication Error occurred	Communication error with the security kernel: <ul style="list-style-type: none"> • Restart the boiler • Replace the CU-GH
H.01.05	Max Delta TF-TR	Maximum difference between flow temperature and return temperature	Maximum difference between the flow and return temperature exceeded: <ul style="list-style-type: none"> • No flow or insufficient flow: <ul style="list-style-type: none"> - Check the flow (direction, pump, valves) - Check the water pressure - Check the cleanliness of the heat exchanger • Sensor error: <ul style="list-style-type: none"> - Check that the sensors are operating correctly - Check that the sensor has been fitted properly

Code	Display text	Description	Solution
H.01.06	Max Delta TH-TF	Maximum difference between heat exchanger temperature and flow temperature	<p>Maximum difference between heat exchanger and flow temperature exceeded:</p> <ul style="list-style-type: none"> • No flow or insufficient flow: <ul style="list-style-type: none"> - Check the circulation (direction, pump, valves). - Check the water pressure. - Check the cleanliness of the heat exchanger. - Check that the installation has been de-aired. - Check water quality according to supplier's specifications. • Sensor error: <ul style="list-style-type: none"> - Check that the sensors are operating correctly. - Check that the sensor has been fitted properly.
H.01.07	Max Delta TH-TR	Maximum difference between heat exchanger temperature and return temperature	<p>Maximum difference between heat exchanger and return temperature exceeded:</p> <ul style="list-style-type: none"> • No flow or insufficient flow: <ul style="list-style-type: none"> - Check the circulation (direction, pump, valves). - Check the water pressure. - Check the cleanliness of the heat exchanger. - Check that the installation has been correctly vented to remove air. • Sensor error: <ul style="list-style-type: none"> - Check that the sensors are operating correctly. - Check that the sensor has been fitted properly.
H.01.08	CH temp grad level3	Maximum CH temperature gradient level3 exceeded	<p>Maximum heat exchanger temperature increase has been exceeded:</p> <ul style="list-style-type: none"> • No flow or insufficient flow: <ul style="list-style-type: none"> - Check the circulation (direction, pump, valves) - Check the water pressure - Check the cleanliness of the heat exchanger - Check that the central heating system has been correctly vented to remove air • Sensor error: <ul style="list-style-type: none"> - Check that the sensors are operating correctly - Check that the sensor has been fitted properly
H.01.09	Gas Pressure Switch	Gas Pressure Switch	<p>Gas pressure too low:</p> <ul style="list-style-type: none"> • No flow or insufficient flow: <ul style="list-style-type: none"> - Make sure that the gas valve is fully opened - Check the gas supply pressure - If a gas filter is present: Make sure that the filter is clean • Wrong setting on the gas pressure switch: <ul style="list-style-type: none"> - Make sure that the switch has been fitted properly - Replace the switch if necessary • No gas pressure switch available: <ul style="list-style-type: none"> - Make sure that parameter GP010 is set to No (0)

Code	Display text	Description	Solution
H.01.13	Max THeat Ex	Heat Exchanger temperature has exceeded the maximum operating value	Maximum heat exchanger temperature exceeded: <ul style="list-style-type: none"> • Check the circulation (direction, pump, valves). • Check the water pressure. • Check that the sensors are operating correctly. • Check that the sensor has been fitted properly. • Check the cleanliness of the heat exchanger. • Check that the central heating system has been correctly vented to remove air.
H.01.14	Max Tflow	Flow temperature has exceeded the maximum operating value	Flow temperature sensor above normal range: <ul style="list-style-type: none"> • Bad connection: check the wiring and connectors • No flow or insufficient flow: <ul style="list-style-type: none"> - Check the circulation (direction, pump, valves) - Check the water pressure - Check the cleanliness of the heat exchanger
H.01.15	Max Tflue Gas	Flue gas temperature has exceeded the maximum operating value	Maximum flue gas temperature exceeded: <ul style="list-style-type: none"> • Check the flue gas outlet system • Check the heat exchanger to ensure that the flue gas side is not clogged • Faulty sensor: replace the sensor
H.01.21	Dhw Temp GradLevel3	Maximum Dhw Temperature Gradient Level3 Exceeded	The flow temperature has risen too fast: <ul style="list-style-type: none"> • Check the flow (direction, pump, valves) • Check that the pump is operating correctly
H.01.26	Gas pressure max	Gas pressure exceeded	Gas pressure too high: <ul style="list-style-type: none"> • Check the gas supply pressure • Wrong setting on the gas pressure switch: <ul style="list-style-type: none"> - Make sure that the switch has been fitted properly - Replace the switch if necessary • No gas pressure switch available: <ul style="list-style-type: none"> - Make sure that parameter GP010 is set to No (0)
H.02.00	Reset In Progress	Reset In Progress	Reset procedure active: <ul style="list-style-type: none"> • No action
H.02.02	Wait Config Number	Waiting For Configuration Number	Configuration error or unknown configuration number: <ul style="list-style-type: none"> • Reset CN1 and CN2
H.02.03	Conf Error	Configuration Error	Configuration error or unknown configuration number: <ul style="list-style-type: none"> • Reset CN1 and CN2
H.02.04	Parameter Error	Parameter Error	Factory settings incorrect: <ul style="list-style-type: none"> • Parameters are not correct: <ul style="list-style-type: none"> - Restart the boiler - Reset CN1 and CN2 - Replace the CU-GH PCB
H.02.05	CSU CU mismatch	CSU does not match CU type	Configuration error: <ul style="list-style-type: none"> • Reset CN1 and CN2
H.02.12	Release Signal	Release Signal input of the Control Unit from device external environment	Waiting time release signal has elapsed: <ul style="list-style-type: none"> • External cause: remove external cause • Wrong parameter set: check the parameters • Bad connection: check the connection
H.02.16	Int CSU Timeout	Internal CSU Timeout	Configuration error: <ul style="list-style-type: none"> • Reset CN1 and CN2 • Replace the PCB

Code	Display text	Description	Solution
H.02.36	Funcnt device lost	Functional device has been disconnected	Communication error with the SCB PCB: <ul style="list-style-type: none"> • Bad connection with BUS: check the wiring. • No PCB: reconnect PCB or retrieve from memory using auto-detect.
H.02.40	Function unavailable	Function unavailable	Contact your supplier
H.02.45	Full Can Conn Matrix	Full Can Connection Matrix	SCB not found: <ul style="list-style-type: none"> • Carry out an auto-detect
H.02.46	Full Can Device Adm	Full Can Device Administration	SCB not found: <ul style="list-style-type: none"> • Carry out an auto-detect
H.02.55	Inval or miss SerNR	Invalid or missing device serial number	Replace the CU-GH PCB
H.02.61	Unsupported function	Zone A doesn't support the selected function	Zone A function setting is not correct or is not allowed on this circuit: <ul style="list-style-type: none"> • Check the setting of parameter CP020.
H.02.62	Unsupported function	Zone B doesn't support the selected function	Zone B function setting is not correct or is not allowed on this circuit: <ul style="list-style-type: none"> • Check the setting of parameter CP021.
H.02.63	Unsupported function	Zone C doesn't support the selected function	Zone C function setting is not correct or is not allowed on this circuit: <ul style="list-style-type: none"> • Check the setting of parameter CP023.
H.02.64	Unsupported function	Zone D doesn't support the selected function	Zone C function (DHW) setting is not correct or is not allowed on this circuit: <ul style="list-style-type: none"> • Check the setting of parameter CP022.
H.02.65	Unsupported function	Zone E doesn't support the selected function	Zone E function (AUX) setting is not correct or is not allowed on this circuit: <ul style="list-style-type: none"> • Check the setting of parameter CP024.
H.02.66	TAS not connected	The anti corrosion protection (TAS) of the Domestic Hot Water tank is not connected	Corrosion protection anode (TAS) not detected: <ul style="list-style-type: none"> • Anode is not connected: Connect the anode • Anode is not connected correctly: Connect the anode correctly
H.02.67	TAS short-circuit	The anti corrosion protection (TAS) of the Domestic Hot Water tank is shortend	Corrosion protection anode (TAS) missing or short-circuited: <ul style="list-style-type: none"> • Bad connection: check the wiring and connectors • Incorrectly fitted sensor: check that the sensor has been correctly fitted • Faulty sensor: replace the sensor
H.02.79	Device lost S-Bus	Connected device not present on system bus	S-Bus connector devices missing: <ul style="list-style-type: none"> • Bad connection: check the wiring and connectors • Incorrectly fitted connectors: check that the connectors has been correctly fitted • End connectors (with resistor) are missing or badly connected: check wiring and connectors • Check if connected devices are activated
H.02.91	CH blocked	CH heatdemand is blocked by the multifunctional input	The blocking input (Block CH) is active. <ul style="list-style-type: none"> • If the error code must not be shown: Make sure Display error is set to No (0).
H.02.92	DHW blocked	DHW heatdemand is blocked by the multifunctional input	The blocking input (Block DHW) is active. <ul style="list-style-type: none"> • If the error code must not be shown: Make sure Display error is set to No (0).
H.02.93	CH and DHW blocked	CH and DHW heatdemands are blocked by the multifunctional input	The blocking input (Block CH+DHW) is active. <ul style="list-style-type: none"> • If the error code must not be shown: Make sure Display error is set to No (0).

Code	Display text	Description	Solution
H.03.00	Parameter Error	Safety parameters level 2, 3, 4 are not correct or missing	Parameter error: security kernel <ul style="list-style-type: none"> Restart the boiler Replace the CU-GH
H.03.01	CU to GVC data error	No valid data from CU to GVC received	Communication error with the CU-GH: <ul style="list-style-type: none"> Restart the boiler
H.03.02	Flame loss detected	Measured ionisation current is below limit	No flame during operation: <ul style="list-style-type: none"> No ionisation current: <ul style="list-style-type: none"> Vent the gas supply to remove air Check that the gas valve is fully opened Check the gas supply pressure Check the operation and setting of the gas valve unit Check that the air supply inlet and flue gas outlet are not blocked Check that there is no recirculation of flue gases
H.03.05	Internal blocking	Gas Valve Control internal blocking occurred	Security kernel error: <ul style="list-style-type: none"> Restart the boiler Replace the CU-GH
H.03.09	Mains voltage low	Supply voltage is below the minimum operating value	<ul style="list-style-type: none"> When the device is switched on or off, an entry is made in the error memory
H.08.07	LIN pump 1 error	LIN pump 1 operation in error	LIN pump 1 operation error: <p> See See LIN pump troubleshooting for solutions</p>
H.08.08	LIN pump 1 lock out	LIN pump 1 operation lock out error	LIN pump 1 operation lock-out error: <ul style="list-style-type: none"> Faulty pump, replace LIN pump 1
H.08.09	LIN pump 1 comm lost	LIN pump 1 communication lost due to failure to communicate with bus master (BDR devices)	LIN pump 1 communication lost due to failure to communicate with bus master: <ul style="list-style-type: none"> Bad connection: check connection Faulty pump, check the LIN pump operation
H.10.00	T Flow Zone A Open	Flow temperature sensor Zone A Open	Flow temperature sensor zone A open: <ul style="list-style-type: none"> Bad connection: check the wiring and connectors Incorrectly fitted sensor: check that the sensor has been correctly fitted Sensor is not present. Faulty sensor: replace the sensor
H.10.01	T Flow Zone A Closed	Flow temperature sensor Zone A Closed	Flow temperature sensor zone A short-circuited: <ul style="list-style-type: none"> Bad connection: check the wiring and connectors Incorrectly fitted sensor: check that the sensor has been correctly fitted Faulty sensor: replace the sensor
H.10.02	T Dhw Zone A Open	Domestic Hot Water temperature sensor Zone A Open	Domestic hot water temperature sensor zone A open: <ul style="list-style-type: none"> Bad connection: check the wiring and connectors Incorrectly fitted sensor: check that the sensor has been correctly fitted Sensor is not present. Faulty sensor: replace the sensor

Code	Display text	Description	Solution
H.10.03	T Dhw Zone A Closed	Domestic Hot Water temperature sensor Zone A Closed	Domestic hot water temperature sensor zone A short-circuited: <ul style="list-style-type: none"> • Bad connection: check the wiring and connectors • Incorrectly fitted sensor: check that the sensor has been correctly fitted • Faulty sensor: replace the sensor • When using thermostat instead of sensor: parameter CP500 must be set to off (=disable)
H.10.04	TSwimmPoolZoneA Open	Swimming Pool Temperature Sensor Zone A Open	Swimming pool temperature sensor A open: <ul style="list-style-type: none"> • Bad connection: check the wiring and connectors • Incorrectly fitted sensor: check that the sensor has been correctly fitted • Sensor is not present. • Faulty sensor: replace the sensor
H.10.05	TSwimmPoolZoneA-Close	Swimming Pool Temperature Sensor Zone A Closed	Swimming pool temperature sensor zone A short-circuited: <ul style="list-style-type: none"> • Bad connection: check the wiring and connectors • Incorrectly fitted sensor: check that the sensor has been correctly fitted • Faulty sensor: replace the sensor
H.10.09	T Flow Zone B Open	Flow temperature sensor Zone B Open	Flow temperature sensor zone B open: <ul style="list-style-type: none"> • Bad connection: check the wiring and connectors • Incorrectly fitted sensor: check that the sensor has been correctly fitted • Sensor is not present. • Faulty sensor: replace the sensor
H.10.10	T Flow Zone B Closed	Flow temperature sensor Zone B Closed	Flow temperature sensor zone B short-circuited: <ul style="list-style-type: none"> • Bad connection: check the wiring and connectors • Incorrectly fitted sensor: check that the sensor has been correctly fitted • Faulty sensor: replace the sensor
H.10.11	T Dhw Zone B Open	Domestic Hot Water Temperature Sensor Zone B Open	Domestic hot water temperature sensor zone B open: <ul style="list-style-type: none"> • Bad connection: check the wiring and connectors • Incorrectly fitted sensor: check that the sensor has been correctly fitted • Sensor is not present. • Faulty sensor: replace the sensor
H.10.12	T Dhw Zone B Closed	Domestic Hot Water temperature sensor Zone B Closed	Domestic hot water temperature sensor zone B short-circuited: <ul style="list-style-type: none"> • Bad connection: check the wiring and connectors • Incorrectly fitted sensor: check that the sensor has been correctly fitted • Faulty sensor: replace the sensor • When using thermostat instead of sensor: parameter CP501 must be set to off (=disable)

Code	Display text	Description	Solution
H.10.13	TSwimmPoolZoneB Open	Swimming Pool Temperature Sensor Zone B Open	Swimming pool temperature sensor B open: <ul style="list-style-type: none"> • Bad connection: check the wiring and connectors • Incorrectly fitted sensor: check that the sensor has been correctly fitted • Sensor is not present. • Faulty sensor: replace the sensor
H.10.14	TSwimmPoolZoneB- Close	Swimming Pool Temperature Sensor Zone B Closed	Swimming pool temperature sensor zone B short-circuited: <ul style="list-style-type: none"> • Bad connection: check the wiring and connectors • Incorrectly fitted sensor: check that the sensor has been correctly fitted • Faulty sensor: replace the sensor
H.10.18	T Flow Zone C Open	Flow temperature sensor Zone C Open	Flow temperature sensor zone C open: <ul style="list-style-type: none"> • Bad connection: check the wiring and connectors • Incorrectly fitted sensor: check that the sensor has been correctly fitted • Sensor is not present. • Faulty sensor: replace the sensor
H.10.19	T Flow Zone C Closed	Flow temperature sensor Zone C Closed	Flow temperature sensor zone C short-circuited: <ul style="list-style-type: none"> • Bad connection: check the wiring and connectors • Incorrectly fitted sensor: check that the sensor has been correctly fitted • Faulty sensor: replace the sensor
H.10.20	T Dhw Zone C Open	Domestic Hot Water Temperature Sensor Zone C Open	Domestic hot water temperature sensor zone C open: <ul style="list-style-type: none"> • Bad connection: check the wiring and connectors • Incorrectly fitted sensor: check that the sensor has been correctly fitted • Sensor is not present. • Faulty sensor: replace the sensor
H.10.21	T Dhw Zone C Closed	Domestic Hot Water temperature sensor Zone C Closed	Domestic hot water temperature sensor zone C short-circuited: <ul style="list-style-type: none"> • Bad connection: check the wiring and connectors • Incorrectly fitted sensor: check that the sensor has been correctly fitted • Faulty sensor: replace the sensor • When using thermostat instead of sensor: parameter CP503 must be set to off (=disable)
H.10.22	TSwimmPoolZoneC Open	Swimming Pool Temperature Sensor Zone C Open	Swimming pool temperature sensor C open: <ul style="list-style-type: none"> • Bad connection: check the wiring and connectors • Incorrectly fitted sensor: check that the sensor has been correctly fitted • Sensor is not present. • Faulty sensor: replace the sensor
H.10.23	TSwimmPoolZoneC- Close	Swimming Pool Temperature Sensor Zone C Closed	Swimming pool temperature sensor zone C short-circuited: <ul style="list-style-type: none"> • Bad connection: check the wiring and connectors • Incorrectly fitted sensor: check that the sensor has been correctly fitted • Faulty sensor: replace the sensor

Code	Display text	Description	Solution
H.10.27	T Flow Zone DHW open	Flow temperature sensor Zone DHW open	Flow temperature sensor zone DHW open: <ul style="list-style-type: none"> • Bad connection: check the wiring and connectors • Incorrectly fitted sensor: check that the sensor has been correctly fitted • Sensor is not present. • Faulty sensor: replace the sensor
H.10.28	Sens zone DHW closed	Flow temperature sensor Zone DHW closed	Flow temperature sensor zone DHW short-circuited: <ul style="list-style-type: none"> • Bad connection: check the wiring and connectors • Incorrectly fitted sensor: check that the sensor has been correctly fitted • Faulty sensor: replace the sensor
H.10.29	Sensor Zone DHW open	Temperature sensor Zone DHW open	Domestic hot water temperature sensor zone DHW open: <ul style="list-style-type: none"> • Bad connection: check the wiring and connectors • Incorrectly fitted sensor: check that the sensor has been correctly fitted • Sensor is not present. • Faulty sensor: replace the sensor
H.10.30	T Zone DHW closed	Domestic Hot Water temperature sensor Zone DHW closed	Domestic hot water temperature sensor zone DHW short-circuited: <ul style="list-style-type: none"> • Bad connection: check the wiring and connectors • Incorrectly fitted sensor: check that the sensor has been correctly fitted • Faulty sensor: replace the sensor • When using thermostat instead of sensor: parameter CP502 must be set to off (=disable)
H.10.36	Sensor Zone AUX open	Flow temperature sensor Zone AUX open	Flow temperature sensor zone AUX open: <ul style="list-style-type: none"> • Bad connection: check the wiring and connectors • Incorrectly fitted sensor: check that the sensor has been correctly fitted • Sensor is not present. • Faulty sensor: replace the sensor
H.10.37	Sens zone AUX closed	Flow temperature sensor ZoneAUX closed	Flow temperature sensor zone AUX short-circuited: <ul style="list-style-type: none"> • Bad connection: check the wiring and connectors • Incorrectly fitted sensor: check that the sensor has been correctly fitted • Faulty sensor: replace the sensor

Code	Display text	Description	Solution
H.10.38	T Dhw Zone AUX open	Domestic Hot Water temperature sensor Zone AUX open	Domestic hot water temperature sensor zone AUX open: <ul style="list-style-type: none"> • Bad connection: check the wiring and connectors • Incorrectly fitted sensor: check that the sensor has been correctly fitted • Sensor is not present. • Faulty sensor: replace the sensor
H.10.39	Sens zone AUX closed	Domestic Hot Water temperature sensor Zone AUX closed	Domestic hot water temperature sensor zone AUX short-circuited: <ul style="list-style-type: none"> • Bad connection: check the wiring and connectors • Incorrectly fitted sensor: check that the sensor has been correctly fitted • Faulty sensor: replace the sensor • When using thermostat instead of sensor: parameter CP504 must be set to off (=disable)

10.1.4 Locking

Tab.76 Locking codes

Code	Display text	Description	Solution
E.00.04	TReturn Open	Return temperature sensor is either removed or measures a temperature below range	Return temperature sensor open: <ul style="list-style-type: none"> • Bad connection: check the wiring and connectors • Incorrectly fitted sensor: check that the sensor has been correctly fitted • Faulty sensor: replace the sensor
E.00.05	TReturn Closed	Return temperature sensor is either shorted or measures a temperature above range	Return temperature sensor short-circuited: <ul style="list-style-type: none"> • Bad connection: check the wiring and connectors • Incorrectly fitted sensor: check that the sensor has been correctly fitted • Faulty sensor: replace the sensor
E.00.06	TReturn Missing	Return temperature sensor was expected but not detected	No connection to temperature return sensor: <ul style="list-style-type: none"> • Bad connection: check the wiring and connectors. • Faulty sensor: replace the sensor
E.00.08	THeat Ex Open	Heat exchanger temperature sensor is either removed or measures a temperature below range	Heat exchanger temperature sensor open: <ul style="list-style-type: none"> • Bad connection: check the wiring and connectors. • Incorrectly fitted sensor: check that the sensor has been correctly fitted. • Faulty sensor: replace the sensor.
E.00.09	THeat Ex Closed	Heat exchanger temperature sensor is either shorted or measures a temperature above range	Heat exchanger temperature sensor short-circuited: <ul style="list-style-type: none"> • Bad connection: check the wiring and connectors. • Incorrectly fitted sensor: check that the sensor has been correctly fitted. • Faulty sensor: replace the sensor.
E.00.16	DHW sensor Open	Domestic Hot Water tank temperature sensor is either removed or measures a temperature below range	Calorifier sensor open: <ul style="list-style-type: none"> • Bad connection: check the wiring and connectors • Faulty sensor: replace the sensor

Code	Display text	Description	Solution
E.00.17	DHW sensor Closed	Domestic Hot Water tank temperature sensor is either shorted or measures a temperature above range	Calorifier sensor short-circuited: <ul style="list-style-type: none"> • Bad connection: check the wiring and connectors • Faulty sensor: replace the sensor
E.00.18	DHW sensor Missing	Domestic Hot Water tank temperature sensor was expected but not detected	An open connection was detected on the DHW cylinder bottom temperature sensor: <ul style="list-style-type: none"> • Bad connection: Check the wiring and connectors. • Incorrectly fitted sensor: Check that the sensor has been correctly fitted. • Faulty sensor: Replace the sensor.
E.00.20	TFlue Gas Open	Flue gas temperature sensor is either removed or measures a temperature below range	Open circuit in flue gas sensor: <ul style="list-style-type: none"> • Bad connection: check the wiring and connectors. • Incorrectly fitted sensor: check that the sensor has been correctly fitted. • Faulty sensor: replace the sensor.
E.00.21	TFlue Gas Closed	Flue gas temperature sensor is either shorted or measures a temperature above range	Flue gas sensor short-circuited: <ul style="list-style-type: none"> • Bad connection: check the wiring and connectors. • Incorrectly fitted sensor: check that the sensor has been correctly fitted. • Faulty sensor: replace the sensor.
E.01.04	5x Flame Loss Error	5x Error of unintended Flame Loss occurrence	Flame loss occurs 5 times: <ul style="list-style-type: none"> • Vent the gas supply to remove air • Check that the gas valve is fully opened • Check the gas supply pressure • Check the operation and setting of the gas valve unit • Check that the air supply inlet and flue gas outlet are not blocked • Check that there is no recirculation of flue gases
E.01.12	Return Higher Flow	Return temperature has a higher temperature value than the flow temperature	Flow and return reversed: <ul style="list-style-type: none"> • Bad connection: check the wiring and connectors • Water circulation in wrong direction: check the circulation (direction, pump, valves) • Incorrectly fitted sensor: check that the sensor has been correctly fitted • Malfunctioning sensor: check the Ohmic value of the sensor • Faulty sensor: replace the sensor
E.01.24	Combustion Error	Several combustion errors occurs with 24 hours	Low ionisation current: <ul style="list-style-type: none"> • Vent the gas supply to remove air. • Check that the gas valve is fully opened. • Check the gas supply pressure. • Check the operation and setting of the gas valve unit. • Check that the air supply inlet and flue gas outlet are not blocked. • Check that there is no recirculation of flue gases.
E.02.13	Blocking Input	Blocking Input of the Control Unit from device external environment	Blocking input is active: <ul style="list-style-type: none"> • External cause: remove external cause • Wrong parameter set: check the parameters

Code	Display text	Description	Solution
E.02.15	Ext CSU Timeout	External CSU Timeout	CSU time out: <ul style="list-style-type: none"> • Bad connection: check the wiring and connectors • Faulty CSU: Replace CSU
E.02.17	GVC CommTimeout	Gas Valve Control unit communication has exceeded feedback time	Communication error with the security kernel: <ul style="list-style-type: none"> • Restart the boiler • Replace the CU-GH
E.02.35	Safety device lost	Safety critical device has been disconnected	Communication fault <ul style="list-style-type: none"> • Carry out an auto-detect
E.02.47	Failed Conn Funct Gr	Failed Connecting Function Groups	Function group not found: <ul style="list-style-type: none"> • Carry out an auto-detect • Restart the boiler • Replace the CU-GH
E.02.90	Room ventilation	Boiler room ventilation timeout. The ventilator did not start or stop in time.	The room was not ventilated within the configured time limit: <ul style="list-style-type: none"> • Incorrect configuration: <ul style="list-style-type: none"> - Check the settings for Boiler room ventilation. - Check the setting for Ventilation timeout. Ensure the time limit is sufficient for the boiler room. • Bad connection: Check the wiring and connectors. • Faulty ventilator: Replace the ventilator.
E.04.00	Parameter error	Safety parameters Level 5 are not correct or missing	Replace the CU-GH.
E.04.01	TFlow Closed	Flow temperature sensor is either shorted or measuring a temperature above range	Flow temperature sensor short circuited: <ul style="list-style-type: none"> • Bad connection: check the wiring and connectors • Incorrectly fitted sensor: check that the sensor has been correctly fitted • Faulty sensor: replace the sensor
E.04.02	TFlow Open	Flow temperature sensor is either removed or measuring a temperature below range	Flow temperature sensor open: <ul style="list-style-type: none"> • Bad connection: check the wiring and connectors • Faulty sensor: replace the sensor
E.04.03	Max Flow temp	Measured flow temperature above safety limit	No flow or insufficient flow: <ul style="list-style-type: none"> • Check the circulation (direction, pump, valves) • Check the water pressure • Check the cleanliness of the heat exchanger
E.04.04	TFlue Closed	Flue temperature sensor is either shorted or measuring a temperature above range	Flue gas temperature sensor short-circuited: <ul style="list-style-type: none"> • Bad connection: check the wiring and connectors • Incorrectly fitted sensor: check that the sensor has been correctly fitted • Faulty sensor: replace the sensor
E.04.05	TFlue Open	Flue temperature sensor is either removed or measuring a temperature below range	Flue gas temperature sensor open: <ul style="list-style-type: none"> • Bad connection: check the wiring and connectors • Incorrectly fitted sensor: check that the sensor has been correctly fitted • Faulty sensor: replace the sensor

Code	Display text	Description	Solution
E.04.06	Max Flue temp	Measured flue temperature above limit	<p>Maximum flue gas temperature exceeded:</p> <ul style="list-style-type: none"> • Check the gas control valve settings. • Flue gas temperature sensor error: <ul style="list-style-type: none"> - Check that the sensor is operating correctly. - Check that the sensor has been fitted properly. • Inspect the heat exchanger: <ul style="list-style-type: none"> - Check the flue gas path. • Replace the heat exchanger.
E.04.07	TFlow Sensor	Deviation in flow sensor 1 and flow sensor 2 detected	<p>Flow temperature sensor deviation:</p> <ul style="list-style-type: none"> • Bad connection: check the connection • Faulty sensor: replace the sensor
E.04.08	Safety input	Safety input is open	<p>Air pressure differential switch activated:</p> <ul style="list-style-type: none"> • Bad connection: check the wiring and connectors • Pressure in flue gas duct is or was too high: <ul style="list-style-type: none"> - Non-return valve does not open - Trap blocked or empty - Check that the air supply inlet and flue gas outlet are not blocked - Check the cleanliness of the heat exchanger
E.04.09	TFlue Sensor	Deviation in flue sensor 1 and flue sensor 2 detected	<p>Flue gas temperature sensor deviation:</p> <ul style="list-style-type: none"> • Bad connection: check the connection • Faulty sensor: replace the sensor
E.04.10	Unsuccessful start	5 Unsuccessful burners starts detected	<p>Five failed burner starts:</p> <ul style="list-style-type: none"> • No ignition spark: <ul style="list-style-type: none"> - Check the wiring between the CU-GH and the ignition transformer - Check the ionisation/ignition electrode - Check breakdown to earth - Check the condition of the burner cover - Check the earthing - Replace the CU-GH • Ignition spark but no flame: <ul style="list-style-type: none"> - Vent the gas pipes to remove air - Check that the air supply inlet and flue gas outlet are not blocked - Check that the gas valve is fully opened - Check the gas supply pressure - Check the operation and setting of the gas valve unit - Check the wiring on the gas valve unit - Replace the CU-GH • Flame present, but ionisation has failed or is inadequate: <ul style="list-style-type: none"> - Check that the gas valve is fully opened - Check the gas supply pressure - Check the ionisation/ignition electrode - Check the earthing - Check the wiring on the ionisation/ignition electrode.
E.04.12	False flame	False flame detected before burner start	<p>False flame signal:</p> <ul style="list-style-type: none"> • The burner remains very hot: Set the O₂ • Ionisation current measured but no flame should be present: check the ionisation/ignition electrode • Faulty gas valve: replace the gas valve • Faulty ignition transformer: replace the ignition transformer

Code	Display text	Description	Solution
E.04.13	Fan	Fan speed has exceeded normal operating range	Fan fault: <ul style="list-style-type: none"> • Bad connection: check the wiring and connectors. • Fan operates when it should not be operating: check for excessive chimney draught • Faulty fan: replace the fan
E.04.15	FlueGas Pipe Blocked	The flue gas pipe is blocked	Flue gas outlet is blocked: <ul style="list-style-type: none"> • Check that the flue gas outlet is not blocked • Restart the boiler
E.04.17	GasValve Driver Err.	The driver for the gas valve is broken	Gas valve unit fault: <ul style="list-style-type: none"> • Bad connection: check the wiring and connectors • Faulty gas valve unit: Replace the gas valve unit
E.04.18	Min Temp Flow Error	The flow temperature is less than the minimum defined by the GVC parameter	The flow temperature sensor has measured a value below the minimum temperature allowed by the GVC: <ul style="list-style-type: none"> • Temperature has increased: Reset the error. • Incorrectly fitted sensor: Check that the sensor has been correctly fitted. • Faulty sensor: Replace the sensor.
E.04.23	Internal Error	Gas Valve Control internal locking	<ul style="list-style-type: none"> • Restart the boiler • Replace the CU-GH
E.04.29	Out of reset	Safety maximum amount of resets exceeded	More than 5 lock-out errors have been reset within 24 hours: <ul style="list-style-type: none"> • Restart the appliance and reset the error.
E.04.254	Unknown	Unknown	Unknown error: <ul style="list-style-type: none"> • Replace the PCB.

10.2 Error history

The control panel has an error history that stores the last 32 errors. Specific details are stored for each error, for example:

- Status
- Sub-status
- Flow temperature
- Return temperature

These details and others can contribute to the error solution.

10.2.1 Reading out and clearing the error history

You can read out the errors on the control panel. The error history can also be cleared.

▶▶ ≡ > **Error History**



Use the rotary knob to navigate.

Use the ✓ button to confirm your selection.

1. Press the ≡ button.
 2. Select **Error History**.
 - Enable installer access if **Error History** is not available.
 - 2.1. Select **Enable installer access**.
 - 2.2. Use code **0012**.
- ⇒ A list up to 32 most recent errors is displayed with:
- The error code.
 - A short description.
 - The date.

Fig.114 Error details

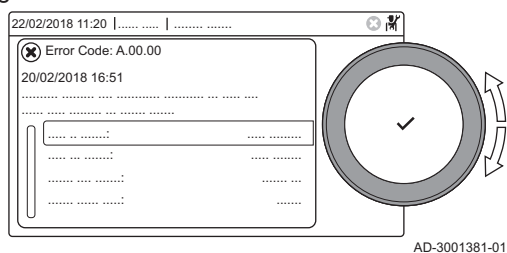

3. Select the error code you want to investigate.
⇒ The display shows an explanation of the error code and several details of the appliance when the error occurred.
4. To clear the error memory, press and hold the ✓ button.

11 User instructions

11.1 Start-up

Start up the boiler as follows:

1. Open the boiler gas tap.
2. Power up the boiler.
3. Check the water pressure of the system. If necessary, top up the system.

The current operating condition of the boiler is shown on the display.

11.2 Accessing the user level menus

The tiles on the home screen provide quick access for the user to the corresponding menus.

Fig.115 Menu selection

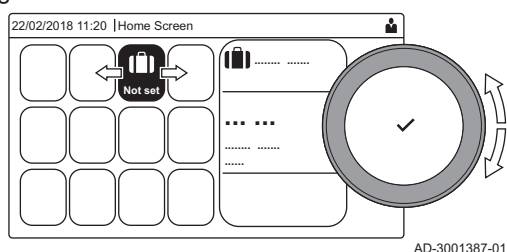

1. Use the rotary knob to select the required menu.

Fig.116 Confirm menu selection

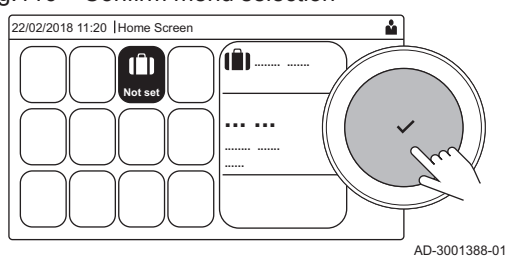

2. Press the ✓ button to confirm the selection.
⇒ The available settings of this selected menu appear in the display.
3. Use the rotary knob to select the desired setting.
4. Press the ✓ button to confirm the selection.
⇒ All options for change will appear in the display (if a setting cannot be changed, **Cannot edit read-only datapoint** will appear in the display).
5. Use the rotary knob to change the setting.
6. Press the ✓ button to confirm the selection.
7. Use the rotary knob to select the next setting or press the ↵ button to return to the home screen.

11.3 Home screen

The tiles on the home screen provide quick access to the corresponding menus. Use the rotary knob to navigate to the menu of your choice and press the ✓ button to confirm the selection. All options for change will appear in the display (**Cannot edit read-only datapoint** will appear in the display if a setting cannot be changed).

Tab.77 Selectable tiles for the user

Tile	Menu	Function
	Information menu	Read out various current values.
	Error indicator	Read out details about the current error. With some errors the icon will appear with installer contact details (when filled in).
	Holiday Mode	Set the start and end date of your holiday to lower the room and domestic hot water temperatures of all zones.
	Operating mode	Change whether your appliance is set to heating, or both, or is turned off.
	Gas boiler indicator	Read out burning details of the boiler and switch the heating function of the boiler on or off.
	Water pressure indicator	Shows the water pressure. Top-up the installation when the water pressure is too low.
	Zone setup	Configure the settings per heating circuit.
	DHW setup	Configure the settings for domestic hot water.
	Outdoor sensor setup	Configure the temperature regulation using the outdoor temperature sensor.
	Cascade settings	Configure the settings for the cascade.

11.4 Activating holiday programs for all zones

When you go on holiday, the room temperature and domestic hot water temperature can be reduced to save energy. Using the following procedure you can activate the holiday mode for all zones and domestic hot water temperature.

- Use the rotary knob to navigate.
- Use the button to confirm your selection.

1. Select the tile .
2. Select **Start date holiday**.
3. Configure the start date.
4. Select **End date holiday**.
⇒ The day after the start date of your holiday is displayed.
5. Configure the end date.
6. Select **Wished room zone temperature on holiday period**.
7. Configure the temperature.

You can reset or cancel the holiday program by selecting **Reset** in the holiday mode menu.

11.5 Heating circuit configuration

For every heating circuit there is a quick user settings menu available. Select the heating circuit you want to configure by selecting the tile or

Tab.78 Menu to configure heating circuit

Menu	Function
Set heating temperatures	Set the temperatures for the time program.
Operating mode	Set the operating mode.
Time programs heating	Set and configure the time programs used when in operating mode Scheduling .
Zone configuration	Configure the settings of the zone circuit.

Tab.79 Extended menu to configure a heating circuit **Zone configuration**

Menu	Function
Short temperature change	Change the room temperature temporarily.
OperatingZoneMode	Select the heating operating mode: Scheduling, Manual.
Manu ZoneRoomTempSet	Set the room temperature manually to a fixed setting.
Holiday Mode	Set the start and end date of your holiday and the reduced temperature for this zone.
Zone friendly Name	Create or change the name of the heating circuit.
Icon display zone	Select the icon of the heating circuit.
ZoneCurrentActivity	Current activity of the zone
ZoneCurrentHeatMode	Displaying current operating mode of the zone

11.6 Changing the heating temperature of a zone

11.6.1 Definition of zone

Fig.117 Two zones

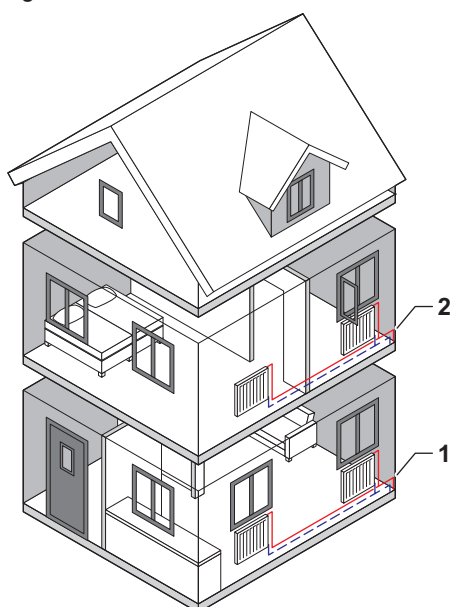

AD-3001404-01

Zone is the term given to the different hydraulic circuits CIRCA, CIRCB and so on. It designates several areas of a building served by the same circuit.

Multiple zones are only possible with an expansion PCB.

Tab.80 Example of two zones

	Zone	Factory name
1	Zone 1	CIRCA
2	Zone 2	CIRCB

11.6.2 Changing the name and symbol of a zone

The zones have a factory set symbol and name. Depending on your appliance you can change the symbol and name for the zones, not all appliances and zone types will support changing the symbol and name.

- ▶▶ Select zone > **Zone configuration** > **Zone friendly Name** or **Icon display zone**
 Installer access enabled: Select zone > **Zone friendly Name** or **Icon display zone**

- 💡 Use the rotary knob to navigate.
 Use the ✓ button to confirm your selection.

1. Select the tile of the zone you want to change.
2. Select **Zone configuration**

- 💡 This menu will not appear if you have installer access enabled, continue to the next step.

3. Select **Zone friendly Name**
 ⇒ A keyboard with letters, numbers and symbols (characters) is shown.

Fig.118 Letter selection

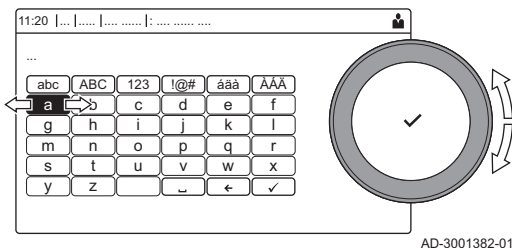

AD-3001382-01

4. Change the name of the zone (20 characters maximum):
 - 4.1. Use the top row to change between capitalisation, numbers, symbols or special characters.
 - 4.2. Select a character or action.
 - 4.3. Select ← to delete a character.
 - 4.4. Select ␣ to add a space.

Fig.119 Finish changing the zone name

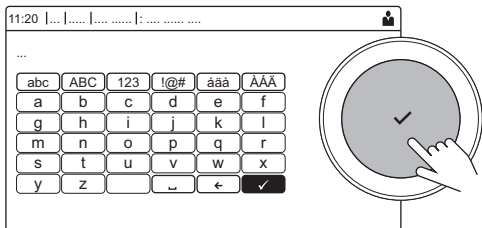

AD-3001383-01

- 4.5. Select ✓ to finish changing the zone name.
5. Select **Icon display zone**.
 - ⇒ All available icons appear in the display.
6. Select the desired icon of the zone.

11.6.3 Changing the operating mode of a zone

To regulate the room temperature of the different areas of the house, you can choose from 5 operating modes:

▶▶ Select zone > **Operating mode**

💡 Use the rotary knob to navigate.
Use the ✓ button to confirm your selection.

1. Select the tile of the zone you want to change.
2. Select **Operating mode**.
3. Select the desired operating mode:

Tab.81 Operating modes

Icon	Mode	Description
	Scheduling	The room temperature is controlled by a time program
	Manual	The room temperature is set to a fixed setting
	Short temperature change	The room temperature is changed temporarily
	Holiday	The room temperature is reduced during your holiday to save energy
	Off	Protect the boiler and installation from freezing in winter

11.6.4 Time program to control the zone temperature

■ Creating a time program

A time program allows you to vary the room temperature per hour and per day. The room temperature is linked to the activity of the time program. You can create up to three time programs per zone. For example, you can create a program for a week with normal working hours and a program for a week when you are at home most of the time.

▶▶ Select zone > **Time programs heating**

💡 Use the rotary knob to navigate.
Use the ✓ button to confirm your selection.

1. Select the tile of the zone you want to change.
2. Select **Time programs heating**.

Fig.120 Weekday

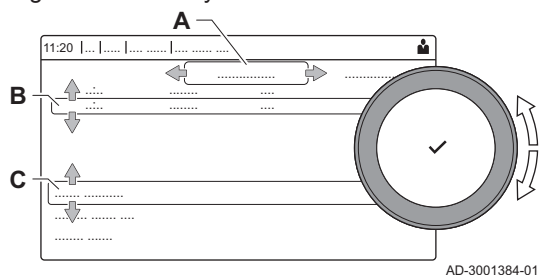

3. Select the time program you want to modify: **Schedule 1, Schedule 2** or **Schedule 3**.
 - ⇒ Activities scheduled for Monday are displayed. The last scheduled activity of a day is active until the first activity of the next day. At initial start-up, all weekdays have two standard activities; **Home** starting at 6:00 and **Sleep** starting at 22:00.
4. Select the weekday you want to modify.
 - A Weekday
 - B Overview of scheduled activities
 - C List of actions
5. Choose one of the following actions:
 - 5.1. Select scheduled activity to edit the time this activity will start, change the temperature or delete the selected activity.
 - 5.2. **Add time and Activity** to add a new activity to the scheduled activities. Deleting times or activities can be done here.
 - 5.3. **Copy to other day** to copy the scheduled activities of the weekday to other days. The activities including the configured time and temperature will be copied to the selected days.
 - 5.4. **Set activity temperatures** to change the temperature.

■ Definition of activity

Activity is the term used when programming time slots in a time program. The time program sets the room temperature for different activities during the day. A temperature setpoint is associated with each activity. The last activity of the day is valid until the first activity of the next day.

Fig.121 Activities of a time program

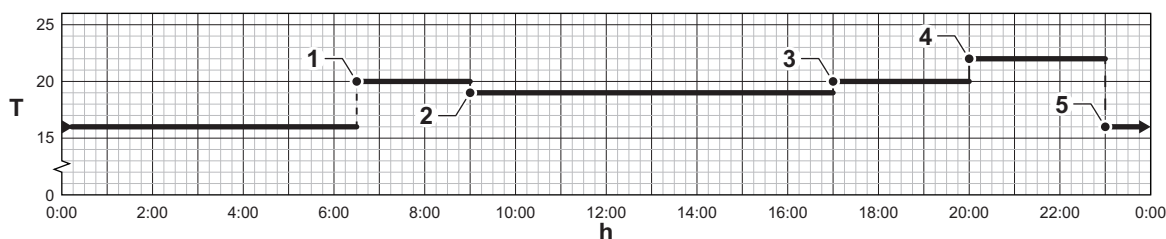

AD-3001403-01

Tab.82 Example of activities

Activity	Start of the activity	Standard name	Temperature setpoint
1	6:30	Morning	20 °C
2	9:00	Away	19 °C
3	17:00	Home	20 °C
4	20:00	Evening	22 °C
5	23:00	Sleep	16 °C
6	-	Custom	-

■ Changing the name of an activity

You can change the names of the activities in the time program.

▶▶ ≡ > **System Settings > Set Heating Activity Names**



Use the rotary knob to navigate.

Use the ✓ button to confirm your selection.

1. Press the ≡ button.
2. Select **System Settings** ⚙️.
3. Select **Set Heating Activity Names**.
 - ⇒ A list of 6 activities and their standard names is shown.
4. Select an activity.
 - ⇒ A keyboard with letters, numbers and symbols is shown.

Fig.122 Letter selection

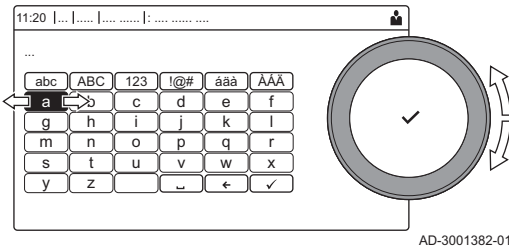

AD-3001382-01

5. Change the name of the activity (20 characters maximum):
 - 5.1. Use the top row to change between capitalization, numbers, symbols or special characters.
 - 5.2. Select a letter, number or action.
 - 5.3. Select ← to delete a letter, number or symbol.
 - 5.4. Select ␣ to add a space.
 - 5.5. Select ✓ to finish changing the activity name.

Fig.123 Confirm sign

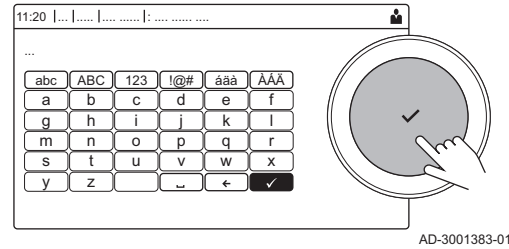

AD-3001383-01

■ Activating a time program

In order to use a time program, it is necessary to activate the operating mode **Scheduling**. This activation is done separately for each zone.

- ▶▶ Select zone > **Operating mode** > **Scheduling**

💡 Use the rotary knob to navigate.
Use the ✓ button to confirm your selection.

1. Select the tile of the zone you want to change.
2. Select **OperatingZoneMode**.
3. Select **Scheduling**.
4. Select the time program **Schedule 1**, **Schedule 2** or **Schedule 3**.

11.6.5 Changing the heating activity temperatures

You can change the heating temperatures of each activity.

- ▶▶ Select zone > **Set heating temperatures**

💡 Use the rotary knob to navigate.
Use the ✓ button to confirm your selection.

1. Select the tile of the zone you want to change.
2. Select **Set heating temperatures**.
⇒ A list of 6 activities and their temperatures is shown.
3. Select an activity.
4. Set the heating activity temperature.

11.6.6 Changing the room temperature temporarily

Regardless of the operating mode selected for a zone, it is possible to change the room temperature for a short period. After this period has elapsed, the selected operating mode resumes.

- ▶▶ Select zone > **Operating mode** > **Short temperature change**

💡 Use the rotary knob to navigate.
Use the ✓ button to confirm your selection.

💡 The room temperature can only be adjusted in this way if a room temperature sensor/thermostat is installed.

1. Select the tile of the zone you want to change.
2. Select **Operating mode**
3. Select 📡 **Short temperature change**.

4. Set the duration in hours and minutes.
5. Set the temporary room temperature.

11.7 Changing the domestic hot water temperature

11.7.1 Domestic hot water configuration

Configure the domestic hot water settings by selecting the tile .



This menu is only available when a domestic hot water system is installed.

Tab.83 Menu to configure domestic hot water

Menu	Function
Domestic Hot Water Setpoints	Set the DHW temperatures for the time program.
DHW mode	Set the operating mode.
Time programs	Set and configure the time programs used when in operating mode Scheduling .
Parameters, counters, signals	Configure the settings of the DHW circuit.

Tab.84 Extended menu to configure the domestic hot water circuit **DHW configuration**

Menu	Function
Hot water boost	Change the DHW temperature temporarily.
Holiday Mode	Set the start and end date of your holiday.
DHW mode	Select the DHW operating mode: Scheduling, Manual.

11.7.2 Changing the domestic hot water operating mode

You can change the operating mode for hot water production. You can choose from 5 operating modes.

▶▶  > **Operating mode**



Use the rotary knob to navigate.
Use the  button to confirm your selection.





1. Select the tile .
2. Select **Operating mode**



This option is not available when installer access is enabled.

3. Select the desired operating mode:

Tab.85 Operating modes



Icon	Mode	Description
	Scheduling	The domestic hot water temperature is controlled by a time program
	Comfort	The domestic hot water temperature is set to a fixed setting
	Hot water boost	The domestic hot water temperature is increased temporarily
	Holiday	The domestic hot water temperature is reduced during your holiday to save energy
	Eco	Protect the appliance and installation from freezing.

11.7.3 Time program to control the DHW temperature

■ Creating a time program

A time program allows you to vary the domestic hot water temperature per hour and per day. The hot water temperature is linked to the activity of the time program.

▶▶  > **Operating mode**

 Use the rotary knob to navigate.
Use the  button to confirm your selection.

 You can create up to three time programs. For example, you can create a program for a week with normal working hours and a programme for a week when you are at home most of the time.

1. Select the tile .
2. Select **Time programs**.
3. Select the time program you want to modify: **Schedule 1**, **Schedule 2** or **Schedule 3**.
⇒ Activities scheduled for Monday are displayed. The last scheduled activity of a day is active until the first activity of the next day. The scheduled activities are shown. At initial start-up, all weekdays have two standard activities; **Comfort** starting at 6:00 and **Eco** starting at 22:00.
4. Select the weekday you want to modify.



- A Weekday
- B Overview of scheduled activities
- C List of actions

5. Perform the following actions:
 - 5.1. **Select scheduled activity** to edit the time this activity will start, change the temperature or to delete the selected activity.
 - 5.2. **Add time and Activity** to add a new activity to the scheduled activities.
 - 5.3. **Copy to other day** to copy the scheduled activities of the weekday to other days.
 - 5.4. **Set activity temperatures** to change the temperature.

■ Activating a DHW time program

In order to use a DHW time program, it is necessary to activate the operating mode **Scheduling**. This activation is done separately for each zone.

▶▶  > **Operating mode** > **Scheduling**

 Use the rotary knob to navigate.
Use the  button to confirm your selection.

1. Select the tile .
2. Select **DHW mode**.
3. Select **Scheduling**.
4. Select **Time programs Schedule 1**, **Schedule 2** or **Schedule 3**.

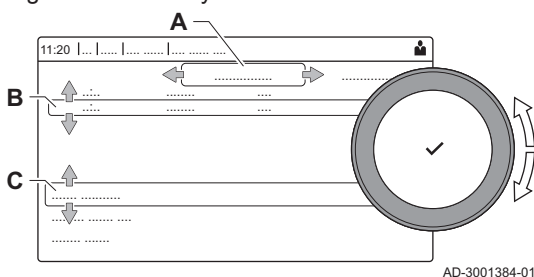

Fig.124 Weekday



11.7.4 Changing the comfort and reduced hot water temperature

You can change the comfort and reduced hot water temperature for the time program.

▶▶  > **Domestic Hot Water Setpoints**

 Use the rotary knob to navigate.
Use the  button to confirm your selection.

1. Select the tile .
2. Select **Domestic Hot Water Setpoints**.

3. Select the setpoint you want to change:
 - **DHW comfort setpoint:** The temperature when the hot water production is switched on.
 - **DHW eco setpoint:** The temperature when the hot water production is switched off.
4. Set the desired temperature.

11.7.5 Increasing the domestic hot water temperature temporarily

Regardless of the operating mode selected for domestic hot water production, it is possible to increase the domestic hot water temperature for a short period. After this period the hot water temperature decreases to the **Eco** setpoint. This is called a hot water boost.

▶▶  > **Operating mode > Hot water boost**





Use the rotary knob to navigate.
Use the  button to confirm your selection.



Important

The domestic hot water temperature can only be adjusted in this way if a domestic hot water sensor is installed.

1. Select the tile .
2. Select **Operating mode**.
3. Select  **Hot water boost**.
4. Set the duration in hours and minutes.
 - ⇒ The temperature is increased to the **DHW comfort setpoint** for the duration of the boost.

11.8 Switching the summer mode on or off

You can use summer mode to switch off the central heating function. While summer mode is active central heating will be turned off but hot water remains available.

▶▶  > **Force summer mode**



Use the rotary knob to navigate.
Use the  button to confirm your selection.



1. Select the tile .
2. Select **Force summer mode**.
3. Select the following setting:
 - **On** to switch on summer mode.
 - **Off** to switch off summer mode.

11.9 Changing the operating mode

You can set the operating mode of your appliance. The modes available may vary per appliance.





Use the rotary knob to navigate.
Use the  button to confirm your selection.

1. Select the tile .
2. Select an operating mode:
 -  **Off** Disable the appliance, does not affect hot water production.
 -  **Heating (auto)** Enable heating.
 - ⇒ The operating mode tile will update to reflect the selected operating mode.

11.10 Changing the control panel settings

You can change the control panel settings within system settings.

▶▶ ≡ > **System Settings**

 Use the rotary knob to navigate.
Use the  button to confirm your selection.

1. Press the ≡ button.
2. Select **System Settings** .
3. Perform one of the operations described in the table below:



Tab.86 Control panel settings

System Settings menu	Settings
Set Date and Time	Set the current date and time
Select Country and Language	Select your country and language
Daylight Saving Time	Enable or disable daylight saving time. When enabled daylight saving time will update the systems internal time to correspond with summer and winter time.
Installer Details	Read out the name and phone number of the installer
Set Heating Activity Names	Create the names for the activities of the time program
Set Screen Brightness	Adjust the brightness of the screen
Set click sound	Enable or disable the click sound of the rotary knob
License Information	Read out detailed license information from the appliance

11.11 Reading the installer's name and phone number

The installer can set his name and phone number in the control panel for your reference. You can find this information by following the steps below:

▶▶ ≡ > **System Settings > Installer Details**

 Use the rotary knob to navigate.
Use the  button to confirm your selection.

1. Press the ≡ button.
2. Select **System Settings** .
3. Select **Installer Details**.
⇒ The installer's name and phone number is shown.

11.12 Frost protection



Notice
Frost damage

Damage to the product.

- Keep the appliance switched on so the frost protection can work. The frost protection does not work if the appliance is switched off.
- Open the valves of all the radiators to protect the entire heating system.
- Install a temperature sensor in the most frost-prone location to protect the entire heating system. The built-in appliance protection will only activate to protect the appliance.
- Drain the appliance and heating system if you will be away from home for a long time and there is a chance of frost.

Set the temperature control low, for example to 10 °C.

If the temperature of the central heating water in the appliance drops too low, the built-in appliance protection system is activated. This system works as follows:

- If the water temperature is lower than 7 °C, the pump switches on.
- If the water temperature is lower than 4 °C, the appliance switches on.
- If the water temperature is higher than 10 °C, the heating stops and the pump continues to run for a short time.

To prevent the system and radiators from freezing in frost-prone locations, a frost protection thermostat or, if feasible, an outdoor temperature sensor can be connected to the appliance.

11.13 Cleaning the casing

1. Clean the outside of the appliance using a damp cloth and a mild detergent.

11.14 Shut-down

Shut-down the boiler as follows:

1. Turn off the boiler using the on/off switch.
2. Shut off the gas supply.
3. Keep the installation frost-free.
Do not shut-down the boiler if the installation can't be kept frost-free.

12 Technical specifications

12.1 Homologations

12.1.1 Certifications

Tab.87 Certifications

CE identification number	PIN 0063DP3280
Class NOx ⁽¹⁾	6
Type of flue gas connection	B ₂₃ , B _{23P} , B ₃₃ ⁽²⁾ C _{13(X)} , C _{33(X)} , C _{43P} , C ₅₃ , C _{63(X)} , C _{93(X)}
(1) EN 15502-1 (2) When installing a boiler with connection type B ₂₃ , B _{23P} , B ₃₃ , the IP rating of the boiler is lowered to IP20.	

12.1.2 Unit categories

Tab.88 Unit categories

Country	Category ⁽¹⁾	Gas type	Connection pressure (mbar)
Austria	II _{2H3B/P}	G20 (H gas) G30/G31 (butane/propane)	20 50
Bulgaria	II _{2H3B/P}	G20 (H gas) G30/G31 (butane/propane)	20 30
Switzerland	II _{2H3B/P}	G20 (H gas) G30/G31 (butane/propane)	20 30-50
Cyprus	I _{3B/P}	G30/G31 (butane/propane)	30-50
Czech Republic	II _{2H3B/P}	G20 (H gas) G30/G31 (butane/propane)	20 30-50
Georgia	II _{2H3B/P}	G20 (H gas) G30/G31 (butane/propane)	20 50
Estonia	II _{2H3P}	G20 (H gas) G31 (propane)	20 30
Finland	II _{2H3B/P}	G20 (H gas) G30/G31 (butane/propane)	20 30
France	II _{2Esi3P}	G20 (H gas) G25 (L gas) G31 (propane)	20 25 37-50
Greece	II _{2H3B/P}	G20 (H gas) G30/G31 (butane/propane)	20 30-50

Country	Category ⁽¹⁾	Gas type	Connection pressure (mbar)
Ireland	II _{2H3P}	G20 (H gas) G31 (propane)	20 30
Italy	II _{2H3B/P}	G20 (H gas) G30/G31 (butane/propane)	20 30
Kazakhstan	II _{2H3B/P}	G20 (H gas) G30/G31 (butane/propane)	20 50
Lithuania	II _{2H3B/P}	G20 (H gas) G30/G31 (butane/propane)	20 30
Luxembourg	II _{2E3P}	G20/G25 (E gas) G31 (propane)	20 50
Latvia	I _{2H}	G20 (H gas)	20
Norway	II _{2H3B/P}	G20 (H gas) G30/G31 (butane/propane)	20 30
Portugal	II _{2H3P}	G20 (H gas) G31 (propane)	20 30-50
Romania	II _{2H3P}	G20 (H gas) G31 (propane)	20 50
Russia	II _{2H3B/P}	G20 (H gas) G30/G31 (butane/propane)	20 30-50
Slovakia	II _{2H3B/P}	G20 (H gas) G30/G31 (butane/propane)	20 30-50
Ukraine	I _{2H}	G20 (H gas)	20
(1) This appliance is suitable for category I _{2E} and I _{2ESi} and I _{2H} containing up to 20% Hydrogen gas (H ₂).			

12.1.3 Directives

In addition to the legal requirements and guidelines, the supplementary guidelines in this manual must also be followed.

Supplements or subsequent regulations and guidelines that are valid at the time of installation shall apply to all regulations and guidelines specified in this manual.

12.1.4 Factory test

Before leaving the factory, each boiler is optimally set and tested for:

- Electrical safety.
- Adjustment of O₂.
- Water tightness.
- Gas tightness.
- Parameter setting.





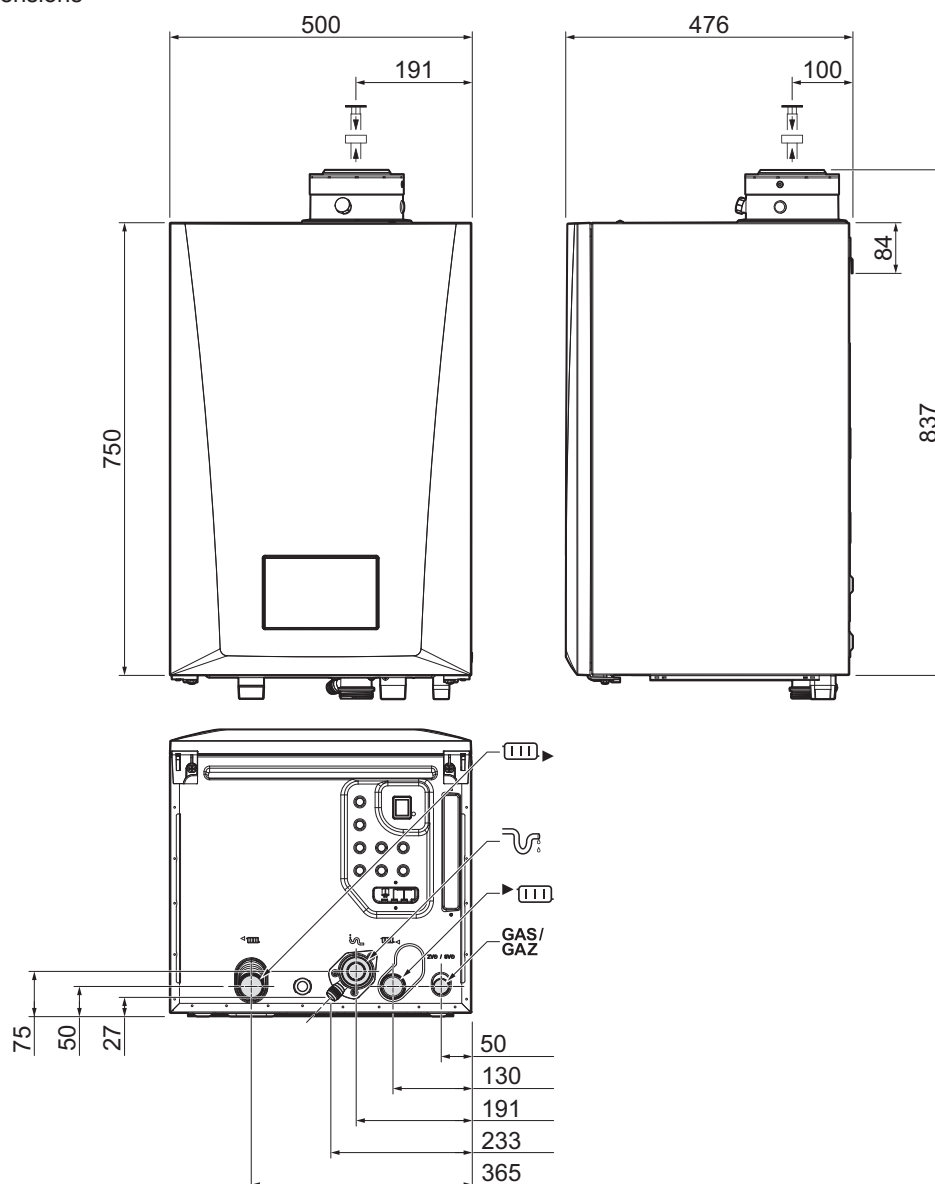

12.2 Dimensions and connections

Fig.125 Dimensions



AD-3002812-01

Tab.89 Connections

	AMC PRO EVO	35 45	65 90 115
	Flue gas outlet connection	Ø 80 mm	Ø 100 mm
	Air inlet connection	Ø 125 mm	Ø 150 mm
	Condensate connection	22.5 mm	22.5 mm
	Flow connection	1 1/4" male thread	1 1/4" male thread
	Return connection	1 1/4" male thread	1 1/4" male thread
	Gas connection	3/4" male thread	3/4" male thread

12.4 Technical data

Tab.90 General

AMC PRO EVO				35	45	65	90	115
Nominal output	P_n 80/60 °C	kW	min max ⁽¹⁾	8.0 33.2	8.0 40.0	12.0 60.9	14.1 84.2	18.9 103.9
Nominal output	P_{nc} 50/30 °C	kW	min max ⁽¹⁾	9.1 35.0	9.1 42.4	13.5 65.0	15.8 89.5	21.2 109.7
Nominal input	Q_{nh} (H_j)	kW	min max ⁽¹⁾	8.2 34.0	8.2 41.2	12.2 62.0	14.6 86.0	19.6 107.0
Nominal input	Propane Q_{nh} (H_j)	kW	min max	8.8 34.0	8.8 41.2	12.2 62.0	22.1 86.0	21.2 107.0
Nominal input	Q_{nh} (H_s)	kW	min max ⁽¹⁾	9.1 37.8	9.1 45.7	13.6 68.9	16.2 95.5	21.9 118.8
Nominal input	Propane Q_{nh} (H_s)	kW	min max	9.6 37.0	9.6 44.8	13.3 67.4	24.0 93.6	23.1 116.4
Reduced input	Q_{Y20h} (H_j)	kW	min max ⁽¹⁾	7.6 31.6	7.6 38.3	11.3 57.7	13.9 80.0	18.2 99.5
Reduced input	Q_{Y20h} (H_s)	kW	min max ⁽¹⁾	8.5 35.2	8.5 42.5	12.6 64.0	15.1 88.8	20.4 110.5
Full load central heating efficiency	P_n (H_j) 80/60 °C	%		97.5	97.2	98.3	97.9	97.1
Full load central heating efficiency	H_j 50/30 °C	%		102.9	102.9	104.6	104.1	102.5
Min load central heating efficiency	H_j RT=60 °C ⁽²⁾	%		97.5	97.2	98.3	96.6	96.5
Part load central heating efficiency	P_n (H_j) RT=30 °C ⁽²⁾	%		108.4	108.4	108.9	108.1	108.0
Full load central heating efficiency	P_n (H_s) 80/60 °C	%		87.8	87.5	88.5	88.2	87.4
Full load central heating efficiency	H_s 50/30 °C	%		92.7	92.7	94.2	93.7	92.3
Min load central heating efficiency	H_s RT=60 °C ⁽²⁾	%		87.8	87.5	88.5	87.0	86.9
Part load central heating efficiency	P_n (H_s) RT=30 °C ⁽²⁾	%		97.6	97.6	98.1	97.3	97.3
(1)  Factory setting.								
(2) Return temperature.								

Tab.91 Gas and flue gas data

AMC PRO EVO				35	45	65	90	115
Gas test pressure	G20	mbar	min max	17 25	17 25	17 25	17 25	17 25
Gas test pressure	G25	mbar	min max	20 30	20 30	20 30	20 30	20 30
Gas test pressure	G31	mbar	min max	37 50	37 50	37 50	37 50	37 50
Gas consumption	G20	m ³ /h	min max	0.8 3.5	0.8 4.3	1.3 6.5	1.5 9.0	2.0 11.1
Gas consumption	G25	m ³ /h	min max	1.0 4.1	1.0 5.0	1.5 7.5	1.7 10.4	2.3 12.9
Gas consumption	G31	m ³ /h	min max	0.3 1.3	0.3 1.6	0.5 2.4	0.8 3.4	0.8 4.2
Gas resistance between boiler connection point and measurement point on the gas control valve	Measured with G20	mbar	max	-	0.4	0.7	0.6	0.8

AMC PRO EVO				35	45	65	90	115
NOx annual emissions	G20 H_s (EN15502)	mg/kWh		33	39	40	54	51
NOx annual emissions ⁽¹⁾	G20 H_s (EN15502)	mg/kWh		33	39	40	54	47
NOx annual emissions	G25 H_s	mg/kWh		29	34	35	52	45
NOx annual emissions	G31 H_s	mg/kWh		47	56	56	59	55
NOx annual emissions ⁽¹⁾	G31 H_s	mg/kWh		47	56	49	59	44
CO annual emissions ⁽¹⁾	G20 H_s (EN15502)	mg/kWh		51	66	64	73	89
CO annual emissions	G25 H_s	mg/kWh		16	20	20	26	29
CO annual emissions ⁽¹⁾	G31 H_s	mg/kWh		61	84	83	80	99
Flue gas amount		kg/h	min max	14 50	14 69	21 104	28 138	36 178
Flue gas temperature		°C	min max	30 65	30 67	30 68	30 68	30 72
Maximum counter pressure for flue gas outlet		Pa		80	150	100	160	220
Flue efficiency	(H_f) 80/60 °C AT=20 °C ⁽²⁾	%		99.3	99.1	99.2	97.9	97.1
Flue losses with burner on	(H_f) 80/60 °C AT=20 °C ⁽²⁾	%		0.7	0.9	0.8	2.1	2.9
(1) For Switzerland. (2) Ambient temperature.								

Tab.92 Central heating circuit data

AMC PRO EVO				35	45	65	90	115
Water content		l		4.3	4.3	6.4	9.4	9.4
Water operating pressure		bar	min	0.8	0.8	0.8	0.8	0.8
Water operating pressure	<i>PMS</i>	bar	max	6.0	6.0	6.0	6.0	6.0
Water temperature		°C	max	110.0	110.0	110.0	110.0	110.0
Operating temperature		°C	max	90.0	90.0	90.0	90.0	90.0
Hydraulic resistance ($\Delta T=20$ K)			mbar	80	114	163	153	250
Casing-related losses		ΔT 30 °C ΔT 50 °C	W	101 201	101 201	110 232	123 254	123 254

Tab.93 Electrical data

AMC PRO EVO				35	45	65	90	115
Supply voltage		V~/Hz		230/50	230/50	230/50	230/50	230/50
Power consumption ⁽¹⁾	Max input CH	W	max	49	71	83	111	169
Power consumption ⁽¹⁾	Max input CH <i>el-max</i>	W	max	49	71	83	111	169
Power consumption ⁽¹⁾	Min input CH	W	min	18	18	23	23	19
Power consumption ⁽¹⁾	Min input CH <i>elmin</i>	W	min	19	19	26	26	24
Power consumption ⁽¹⁾	Standby	W	max	4	4	4	4	5
Electrical protection index ⁽²⁾		IP		X4D	X4D	X4D	X4D	X4D
Electrical shock protection type	Class			I	I	I	I	I

AMC PRO EVO				35	45	65	90	115
Fuse – CU-GH22		(AT)		2.5	2.5	2.5	2.5	2.5
Fuse – CB		(AT)		6.3	6.3	6.3	6.3	6.3
(1) Without pump. (2) For a room-sealed system.								

Tab.94 Other data

AMC PRO EVO				35	45	65	90	115
Total weight with packaging		kg		61	61	67	76	77
Minimum mounting weight	Without front panel	kg		52	52	58	67	68
Average acoustic level at a distance of 1 metre from the boiler ⁽¹⁾	LpA	dB(A)		42.0	45.1	46.7	51.6	51.1
Average acoustic level ⁽¹⁾	LwA	dB(A)		52.0	53.1	54.7	59.5	59.1
(1) For a sealed installation.								

Tab.95 Technical parameters

AMC PRO EVO				35	45	65	90	115
Condensing boiler				Yes	Yes	Yes	Yes	Yes
Low-temperature boiler ⁽¹⁾				No	No	No	No	No
B1 boiler				No	No	No	No	No
Cogeneration space heater				No	No	No	No	No
Combination heater				No	No	No	No	No
Rated heat output	<i>P_{rated}</i>	kW		33	40	61	84	104
Useful heat output at nominal heat output and high temperature operation ⁽²⁾	<i>P₄</i>	kW		33.2	40.0	60.9	84.2	103.9
Useful heat output at 30% of rated heat output and low temperature regime ⁽¹⁾	<i>P₁</i>	kW		11.1	13.4	20.2	27.9	34.7
Seasonal space heating energy efficiency	η_s	%		92	93	93	-	-
Useful efficiency at rated heat output and high temperature regime ⁽²⁾	η_4	%		87.8	87.5	88.5	88.2	87.4
Useful efficiency at 30% of rated heat output and low temperature regime ⁽¹⁾	η_1	%		97.6	97.6	98.1	97.3	97.3
Auxiliary electricity consumption								
Full load	<i>el_{max}</i>	kW		0.049	0.071	0.083	0.111	0.169
Part load	<i>el_{min}</i>	kW		0.018	0.018	0.023	0.023	0.019
Standby mode	<i>P_{SB}</i>	kW		0.004	0.004	0.004	0.004	0.005
Other items								
Standby heat loss	<i>P_{stby}</i>	kW		0.101	0.101	0.110	0.123	0.123
Ignition burner power consumption	<i>P_{ign}</i>	kW		-	-	-	-	-
Annual energy consumption	<i>Q_{HE}</i>	kWh GJ		103	124	189	-	-
Sound power level, indoors	<i>L_{WA}</i>	dB		52	53	55	60	59
Emissions of nitrogen oxides	NO _x	mg/kWh		33	39	40	54	51
(1) Low temperature means 30 °C for condensing boilers, 37 °C for low temperature boilers and 50 °C (at heater inlet) for other heating appliances. (2) High temperature operation means 60 °C return temperature at heater inlet and 80 °C feed temperature at heater outlet.								

**See**

Refer to the back cover for contact details.

12.5 Hydraulic resistance

Take the boiler resistance and system resistance into account when selecting a pump. The graph shows the hydraulic resistance at various water flow rates. The table shows some significant nominal flow data and the corresponding hydraulic resistance.

Fig.127 Hydraulic resistance

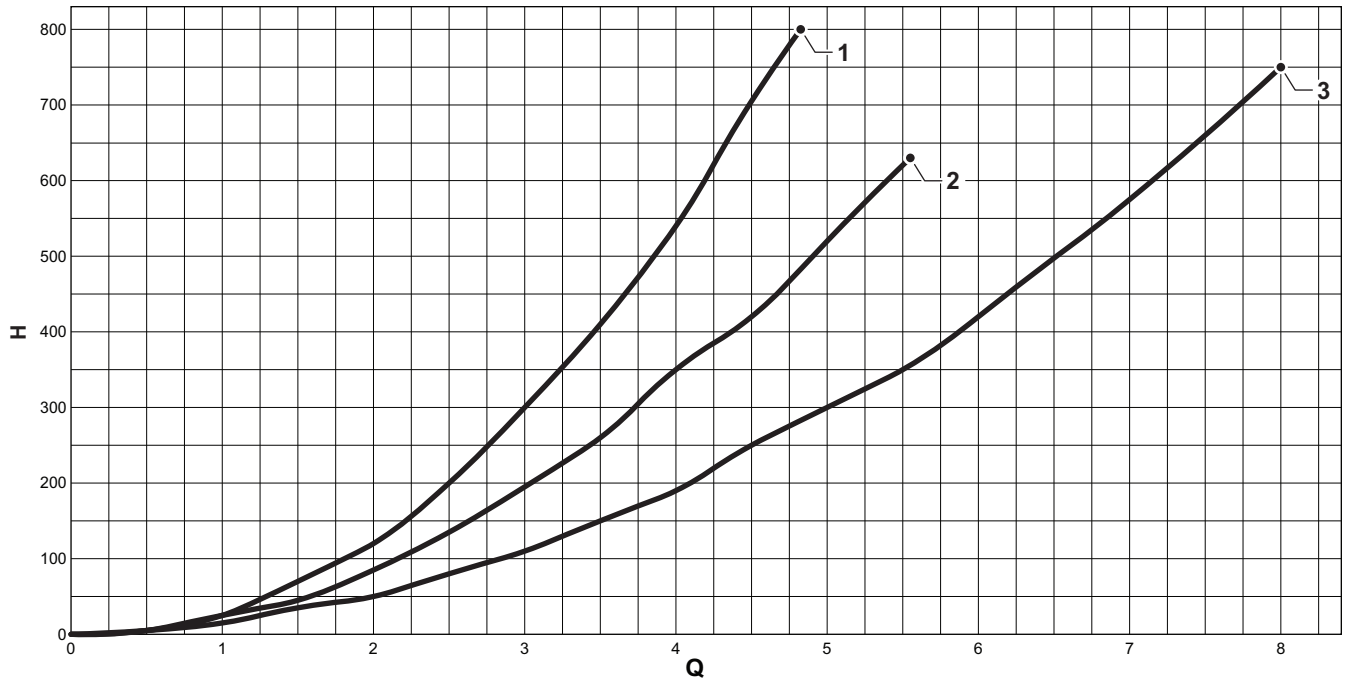

AD-3002814-01

- Q** Water flow (m³/h)
- H** Hydraulic resistance (mbar)
- 1** AMC PRO EVO 35 - 45
- 2** AMC PRO EVO 65
- 3** AMC PRO EVO 90 - 115

Tab.96 Nominal flow data

	Unit	35	45	65	90	115
Q at ΔT = 10 °C	m ³ /h	2.90	3.50	5.28	7.20	9.0
H at ΔT = 10 °C	mbar	320	456	652	612	1000
Q at ΔT = 20 °C	m ³ /h	1.45	1.75	2.64	3.60	4.50
H at ΔT = 20 °C	mbar	80	114	163	153	250
Q at ΔT = 35 °C	m ³ /h	-	-	-	-	2.55
H at ΔT = 35 °C	mbar	-	-	-	-	72
Q at ΔT = 40 °C	m ³ /h	0.73	0.90	1.32	1.80	-
H at ΔT = 40 °C	mbar	18	30	45	40	-

13 Appendix

13.1 ErP information

13.1.1 Product fiche

Tab.97 Product fiche

De Dietrich – AMC PRO EVO		35	45	65	90	115
Seasonal space heating energy efficiency class		A	A	A	-	-
Rated heat output (<i>Prated</i> or <i>Psup</i>)	kW	33	40	61	84	104

De Dietrich – AMC PRO EVO		35	45	65	90	115
Seasonal space heating energy efficiency	%	92	93	93	-	-
Annual energy consumption	GJ	103	124	189	-	-
Sound power level L_{WA} indoors	dB	52	53	55	60	59

**See**

For specific precautions in relation to assembly, installation and maintenance: Safety, page 6

13.1.2 Package fiche

Fig.128 Package fiche for boilers indicating the space heating energy efficiency of the package

Seasonal space heating energy efficiency of boiler ①
'I' %

Temperature control
 from fiche of temperature control

Class I = 1%, Class II = 2%, Class III = 1.5%,
 Class IV = 2%, Class V = 3%, Class VI = 4%,
 Class VII = 3.5%, Class VIII = 5%

②
 + %

Supplementary boiler
 from fiche of boiler

Seasonal space heating energy efficiency (in %)

③
 (- 'I') x 0.1 = ± %

Solar contribution
 from fiche of solar device

Collector size (in m²)

Tank volume (in m³)

Collector efficiency (in %)

Tank rating ⁽¹⁾
 A* = 0.95, A = 0.91,
 B = 0.86, C = 0.83,
 D - G = 0.81

('III' x + 'IV' x) x 0.9 x (/100) x = + %

④

(1) If tank rating is above A, use 0.95

Supplementary heat pump
 from fiche of heat pump

Seasonal space heating energy efficiency (in %)

⑤
 (- 'I') x 'II' = + %

Solar contribution AND Supplementary heat pump
 select smaller value

0.5 x OR 0.5 x = - %

⑥

Seasonal space heating energy efficiency of package ⑦
 %

Seasonal space heating energy efficiency class of package

<input type="checkbox"/>	<input type="checkbox"/>	<input type="checkbox"/>	<input type="checkbox"/>	<input type="checkbox"/>	<input type="checkbox"/>	<input type="checkbox"/>	<input type="checkbox"/>	<input type="checkbox"/>	<input type="checkbox"/>
G	F	E	D	C	B	A	A⁺	A⁺⁺	A⁺⁺⁺
<30%	≥30%	≥34%	≥36%	≥75%	≥82%	≥90%	≥98%	≥125%	≥150%

Boiler and supplementary heat pump installed with low temperature heat emitters at 35°C ?
 from fiche of heat pump

⑦
 + (50 x 'II') = %

The energy efficiency of the package of products provided for in this fiche may not correspond to its actual energy efficiency once installed in a building, as this efficiency is influenced by further factors such as heat loss in the distribution system and the dimensioning of the products in relation to building size and characteristics.

AD-3000743-01

- I The value of the seasonal space heating energy efficiency of the preferential space heater, expressed in %.
- II The factor for weighting the heat output of preferential and supplementary heaters of a package as set out in the following table.

- III The value of the mathematical expression: $294/(11 \cdot \text{Prated})$, whereby 'Prated' is related to the preferential space heater.
 IV The value of the mathematical expression $115/(11 \cdot \text{Prated})$, whereby 'Prated' is related to the preferential space heater.

Tab.98 Weighting of boilers

$P_{sup} / (Prated + P_{sup})^{(1)(2)}$	II, package without hot water storage tank	II, package with hot water storage tank
0	0	0
0.1	0.3	0.37
0.2	0.55	0.70
0.3	0.75	0.85
0.4	0.85	0.94
0.5	0.95	0.98
0.6	0.98	1.00
≥ 0.7	1.00	1.00

(1) The intermediate values are calculated by linear interpolation between the two adjacent values.
 (2) Prated is related to the preferential space heater or combination heater.

13.2 EC Declaration of conformity

This appliance complies with the standard type described in the EC declaration of conformity. It has been manufactured and commissioned in accordance with European directives.

 You can go to the website for the declaration of conformity: <https://declaration-of-conformity.bdrthermeagroup.com>

Fig.129 QR code



AD-3001616-01

Original instructions - © Copyright

All technical and technological information contained in these technical instructions, as well as any drawings and technical descriptions supplied, remain our property and shall not be multiplied without our prior consent in writing. Subject to alterations.

DE DIETRICH SERVICE

AT

0800 / 201608

www.dedietrich-heiztechnik.com

BDR THERMEA (SLOVAKIA) S.Ŕ.O

SK

Hroznová 2318, 91105 Trenčín

+421 907 790 221

info@baxi.sk

www.dedietrichsk.sk

BDR THERMEA (Czech republic) s.r.o

CZ

Jeseniova 2770/56

130 00 Praha 3

+420 271 001 627

dedietrich@bdrthermea.cz

www.dedietrich.cz

BDR THERMEA ROMANIA SRL

RO

Bd. Dimitrie Pompeiu nr. 5-7, Metrooffice A2,

Parter, 13a, Sector 2, 020335 București,

România

0374.424.800

office@bdrthermea.ro

www.bdrthermea.ro

HS Tarm A/S

DK

Smedevej 2

6880 Tarm

+45 97 37 15 11

info@hstarm.dk

www.hstarm.dk

ООО "БДР ТЕРМИЯ РУС"

RU

129164, РФ, Москва,

Зубарев переулок, 15/1

+7 (495) 733-95-82

info@dedietrich.ru

www.dedietrich.ru

DUEDI S.r.l.

IT

Via Maestri del Lavoro, 16

12010 San Defendente di Cervasca (CN)

+39 0171 857170

info@duediclima.it

www.duediclima.it



CE

EAC

089-20



DE DIETRICH

FR

Direction de la Marque

57, rue de la Gare

F-67580 Mertzwiller

0 809 400 320

www.dedietrich-thermique.fr

De Dietrich

